

LEADER TEST INSTRUMENTS

MODEL LBO-524•LBO-524L

**40MHz DUAL TIME BASE
DELAYED SWEEP OSCILLOSCOPE**

INSTRUCTION MANUAL

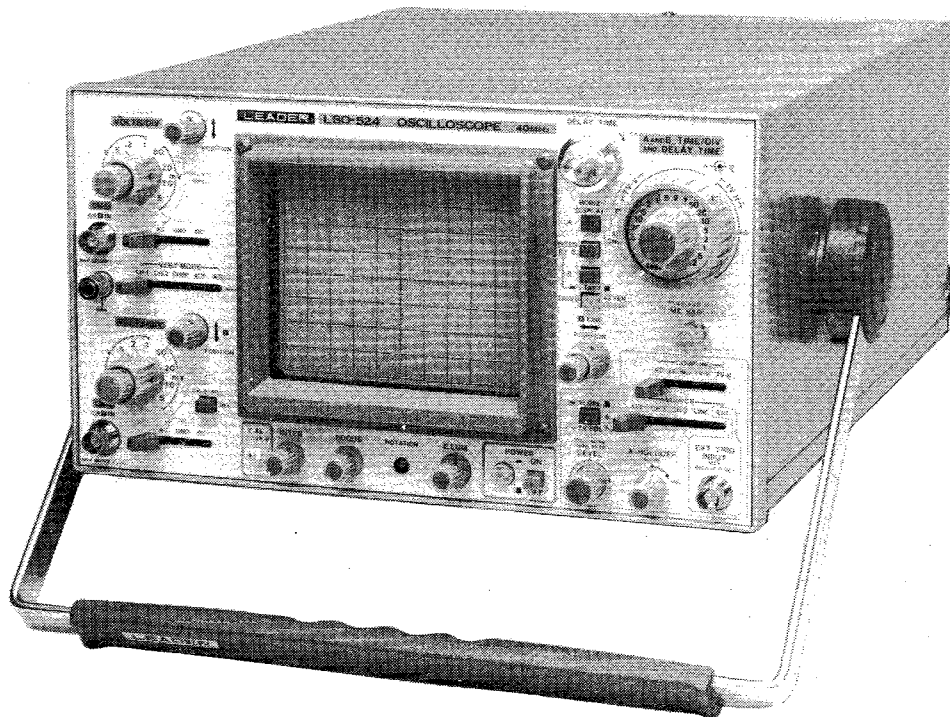

LEADER ELECTRONICS CORP.

LBO-524 · LBO-524L
40MHz DUAL TIME BASE DELAYED SWEEP OSCILLOSCOPE
TABLE OF CONTENTS

1. INTRODUCTION	1
2. SPECIFICATION	2
3. NOTES ON OPERATION	3
3.1 Power Source Voltage	3
3.2 Signal Input	3
3.3 Influence of Strong Magnetic Field	3
3.4 Operation in a Hot and Humid Place	3
3.5 Intensity of CRT	3
3.6 Notes on Connection with a Trans-less Equipment	4
4. DESCRIPTION ON PANEL	4
4.1 General Appearance	5
4.2 Display Block	5
4.3 Vertical Block	5
4.4 Synchronizing Block	7
4.5 Sweep Block	8
4.6 Rear Panel	10
5. BASIC OPERATIONS	11
5.1 How to Display Trace Line	11
5.2 Gain Checking Calibration Waveform	13
5.3 How to Use a Low-capacitance/Direct Probe	13
5.3.1 Specifications	
5.3.2 Operation of low capacitance probe	
5.3.3 Adjustment of probe	
5.4 Note on Direct Connection and Use of Probe	14
5.5 Ground Connection	14
5.6 Dual Trace Measurement	14
5.6.1 ALT.	
5.6.2 CHOP	
5.7 Synchronization to Waveforms	14
5.7.1 Mode of synchronizing sweep	
5.7.2 Selection of synchronizing signal source	
5.7.3 Coupling of synchronizing signals	
5.7.4 Selection of synchronization position	
5.7.5 B TIME synchronization	
5.8 CH-1 OUTPUT	18

6. MEASUREMENTS	19
6.1 AC Peak Voltage	19
6.2 DC Voltage	19
6.3 DC + AC Peak Voltage	19
6.4 Time Interval Measurement	19
6.5 Frequency Measurement	20
6.6 Rise Time of Pulse	20
6.6.1 Measurement by A sweep only	
6.6.2 Measurement by B sweep (delayed sweep)	
6.6.3 On Maximum sweep, 0.2 μ s/div. for both A and B [LBO-524L]	
6.7 Phase Difference between Two Signals	22
6.8 Measurement of Phase Difference by X-Y Operation	22
6.9 Intensity Modulation Terminal (Z axis)	23
7. MAINTENANCE CALIBRATION BY THE USERS	23
8. INTERNAL MAINTENANCE CALIBRATION BY SPECIALISTS	23
8.1 Layout of Main Parts and Adjusters	23
8.1.1 Layout of main parts	
8.1.2 Layout of adjusters	
8.2 Adjustments of Main Adjusters	25
8.2.1 Vertical gain	
8.2.2 Vertical DC balance	
8.2.3 ASTIG	
8.2.4 Calibration of time axis	
9. CONNECTION DIAGRAM AND SCHEMATICS	26

1. INTRODUCTION

The LBO-524[L] Oscilloscope is a portable one with the functions of 5 mV/div. (40 MHz), 500 μ V/div. (5 MHz), maximum sweep ratio 20 ns/div. (MAG x 10), and delayed sweep, equipped with a 6-inch rectangular metal-back CRT with high brightness, internal graticule and the vertical sensitivity magnifier.

The LBO-524[L] have a wide range of application in production and service areas for measurements and testings of TV set, VTRs and computer peripheral equipments, since the TV synchronization separator, variable hold off and V-AXIS magnifier functions are provided.

2. SPECIFICATIONS

CRT Display	
Type	150 mm Rectangular, Internal-graticule Scale, Aluminized Screen and Flat Face with illumination lamp and Percentage scale.
Accelerating Potential	7 kV/2 kV regulated
Effective display area	8 x 10 div. (1 div. = 10 mm)
Beam Rotator	Adjustment on front panel
Graticule Illumination	Continuously variable
Intensity Modulation	Blanked by TTL Level Signal
Vertical Amplifiers (CH-1 and 2)	
Sensitivity	5 mV/div. to 5V/div. (all bandwidth), 0.5 mV/div. to 2 mV/div. (5 MHz: MAG x 10) with variable in 10 steps, 1-2-5 sequence, continuously variable between steps.
Calibration Accuracy	$\pm 3\%$ ($\pm 5\%$: MAG x 10)
Bandwidth (-3 dB, 8 div.)	
DC coupled	DC to 40 MHz (DC to 5 MHz: MAG x 10)
AC coupled	10 Hz to 40 MHz
Rise Time	9 ns (70 ns: MAG x 10)
Input Impedance	1 M Ω \pm 1.5%, 30 pF within \pm 5 pF (Tolerance: within \pm 2 pF)
Input Coupling	AC, GND, DC
Maximum Input	600V (DC + ACp-p)
Signal Delay [LBO-524L]	Leading edge displayed.
Display Modes	CH-1, CH-2, CHOP, ALT, ADD
Polarity Invert	CH-2 INVERT
CH-1 Output	Approx. 0.1V/div. in to 50 Ω (DC to 40 MHz, -3 dB)
Horizontal Amplifier	
Sweep Method	Trigger sweep, Automatic trigger sweep, Continuously delayed sweep, and Trigger delayed sweep
A Sweep Time	0.2 μ s/div. to 0.2 s/div., 1-2-5 sequence 19 steps with continuous adjuster.
B Sweep Time	0.2 μ s/div. to 0.5 ms/div., 1-2-5 sequence 11 steps.
Calibration Accuracy	$\pm 3\%$
Hold-off variable	One sweep or more
Delay Time Jitter	1/10,000
Setting accuracy of delay time position	$\pm 3\%$ approx.
Magnifier	10 times $\pm 5\%$
Max. Sweep Time	20 ns/div. (MAG x 10 ON)

Synchronization
 Signal Sources
 Coupling
 Slope
 Sensitivity

ALT, CH-1, CH-2, LINE, EXT.
 AC, HF-REJ, TV-V, TV-H
 + or -

	Bandwidth	INT.	EXT.
NORM	30 Hz - 10 MHz	0.5 div.	0.2Vp-p
	2 Hz - 10 MHz	1.5 div.	0.6Vp-p
AUTO	30 Hz - 10 MHz	0.5 div.	0.2Vp-p
	30 Hz - 40 MHz	1.5 div.	0.6Vp-p

TV Synchronization

Extracts the synchronizing signal from composite video signal and provides stable synchronization. Slope switch is selected according to polarity of video signals.

X-Y Mode (X=CH-1, Y=CH-2)
 Sensitivity

X axis: 5 mV/div. to 5V/div.
 Y axis: 5 mV/div. to 5V/div.
 DC or 10 Hz to 1 MHz (-3 dB, ref. 8 div.)
 Less than 3° at 100 kHz

X axis Bandwidth
 X-Y phase

Calibrator

Output Voltage
 Frequency

0.5Vp-p ±2%
 Approx. 1 kHz, square wave

Power Requirements

Line Voltage
 Power Consumption

AC 100, 120, 200, 220, 240V 50/60 Hz
 50W

Size and Weight

160(H) x 290(W) x 375(D) mm, 8.5 kg

Supplied Accessories

Direct/Low capacitance probe LP-16BX 2
 BNC terminal adapter 2
 Time lag fuse 1
 Instruction manual 1

Optional Accessories

Protective front cover
 Accessories pouch

3. NOTES ON OPERATION

3.1 Power Source Voltage

Apply the AC power of a voltage that is within $\pm 10\%$ variation of the rated voltage as given in the table below. Operating at a voltage below 10% or more variation of rated value may result in improper performance of the LBO-524[L]. A voltage applied more than 10% variation of the rated value may damage the power supply circuitry. The built-in power transformer has taps of 100 and 120V. Five different types of voltage ratings can be selected by rewiring the taps as shown in the

figures shown below. Note the fuse rating and type when the power voltage is changed.

Rating voltage	Voltage range ($\pm 10\%$)	Fuse rating
100V 120V	90 ~ 110V 110 ~ 130V	} 1A TIME LAG
200V 220V 240V	180 ~ 220V 200 ~ 240V 220 ~ 260V	

Terminal Arrangement and Wiring Diagram of the Power Transformer

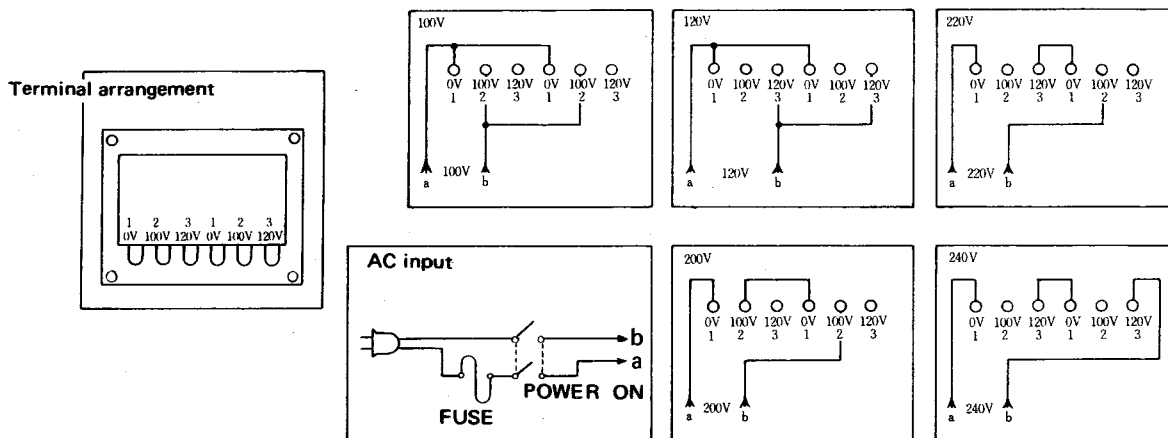

3.2 Signal Input

Input signals higher than 600V (ACp-p + DC), applied to terminals, may damage circuit components.

The maximum allowable input voltage is:

Vertical input terminals

⑩, ⑳ INPUT: Max. 600V (ACp-p + DC)

External synchronization signal-input terminal

⑳ TRIG. or H IN: Same as the above

Probe input (LP-16BX): Same as the above

3.3 Influence of Strong Magnetic Field

Operation in a strong magnetic field will cause distortion or swing of display waveforms or make an excessive decline of traces when the instrument is used near an equipment or transformer of large power consumption. Therefore avoid to use the instrument near such a magnetic field source.

3.4 Operation in a Hot and Humid Place

The instrument is designed to operate in a temperature range of 0°C to $\pm 40^{\circ}\text{C}$ and relative humidity range of 10 to 90%. Operation in a severe environment may shorten the life of the instrument.

3.5 Intensity of CRT

Burn-resisting fluorescent (phosphor) material is used in the CRT. But if the CRT is left with a bright dot or trace, or with unnecessarily raised intensity, its fluorescent screen may be damaged. When observing waveforms, therefore, the intensity should be maintained at the minimum necessary level. If the instrument is to be left with the power on for a long period of hours, lower the intensity and obscure the focus.

3.6 Notes on Connection with a Trans-less Equipment

The chassis of a trans-less equipment may be applied with the primary power line voltage. When the oscilloscope is connected with such an equipment, care must be taken for the electric shock which is hazardous.

Particularly when the system is grounded to the earth for the measurement of C-MOS circuits

or the like, the instrument in the system or the device to be tested may be damaged by shorted circuit.

The safest method of making the connection is to use an isolation transformer of 1:1 ratio as shown below.

When the system is to be grounded, connect the earth line to the ground terminal of the LBO-524[L].

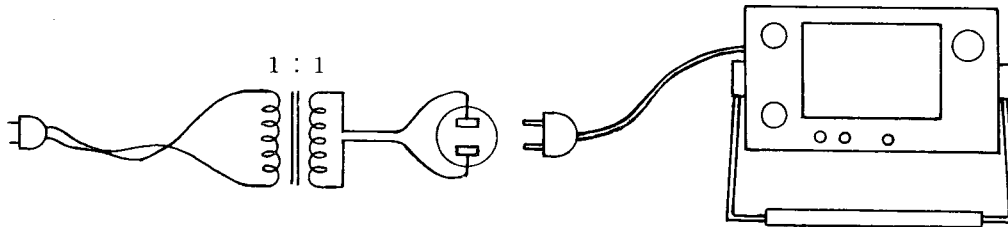

4. DESCRIPTION ON PANEL

In this instruction manual, numerals in circles indicate control knobs, switches, and the like.

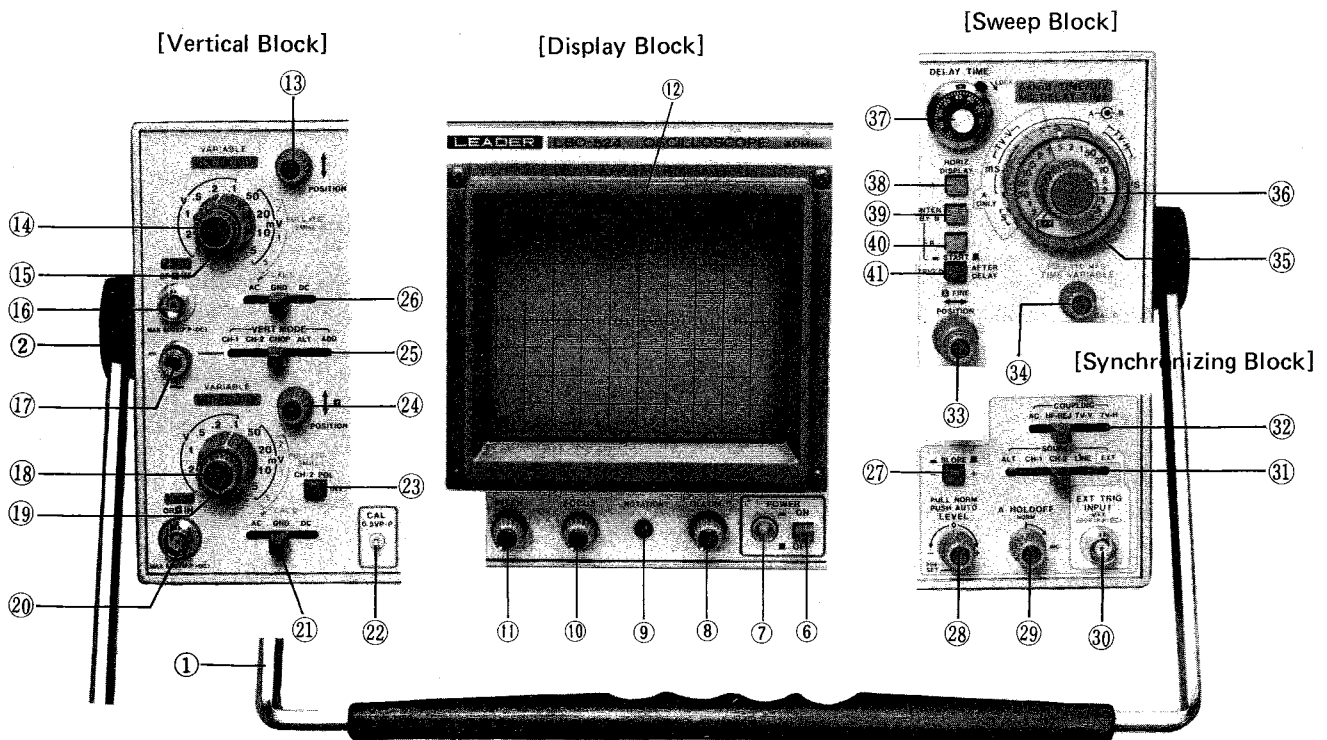

4.1 General Appearance

- ① Hand carrier
- ② Hand carrier stopper:
Locks the hand carrier at 22.5°. Firmly press in each stopper with both hands, the hand carrier will be unlocked and rotate freely. Upon release the hand carrier will revert to locked position.
- ③ Legs for vertical viewing and AC cord winding:
These are legs for vertical viewing and AC cord winding convenience. To store or shorten AC cord wind around legs.

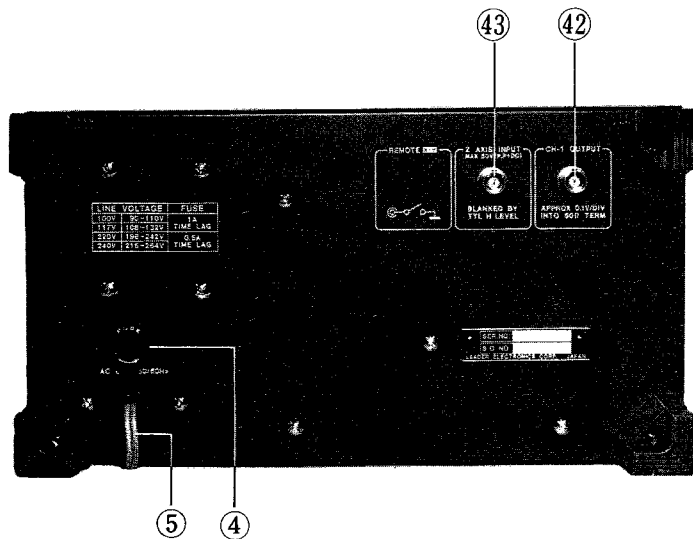
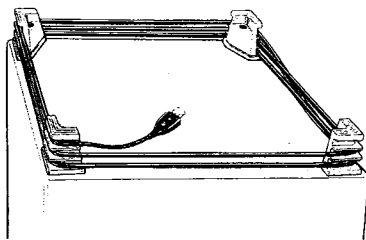

- ④ FUSE:
When the cap is turned to the counterclockwise direction with plus-type screwdriver, the fuse can be removed. Note the type and rating of the fuse used.

- ⑤ Power cord.

4.2 Display Block

- ⑥ Power ON/ OFF switch:
Push in to turn instrument power on and off.
- ⑦ Pilot lamp:

[Display Block]

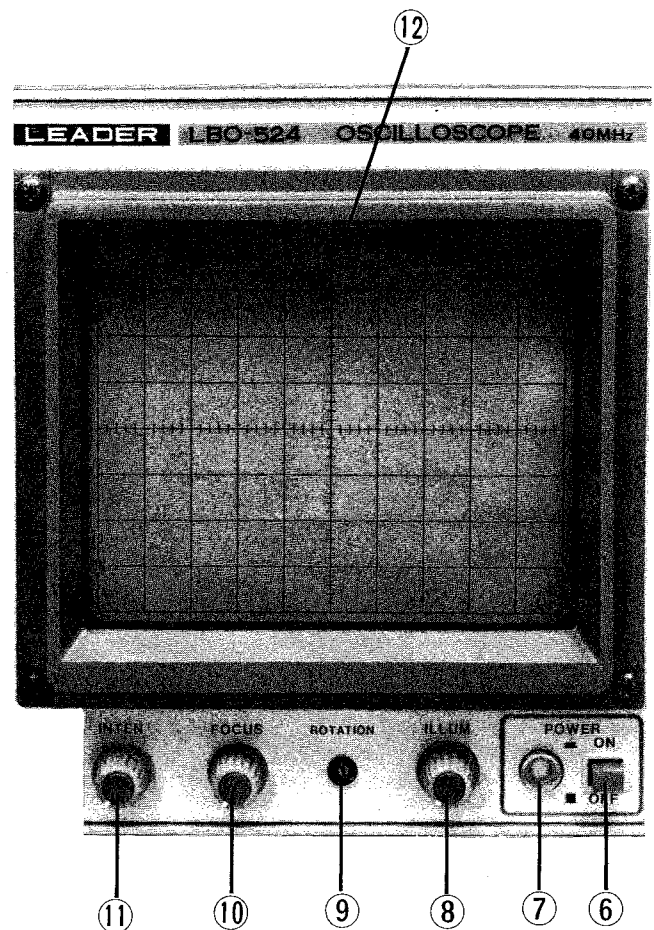

- ⑧ ILLUM control:
To adjust graticule illumination. Clockwise rotation increases brightness.
- ⑨ ROTATION control:
Adjust the ROTATION screw adjuster using a screwdriver, when the trace line is not horizontal.
- ⑩ FOCUS control:
To attain maximum trace sharpness.
- ⑪ INTEN control:
To adjust the overall brightness of the CRT display. Clockwise rotation increases brightness.
- ⑫ Graticule

4.3 Vertical Block

- ⑬ CH-1 Vertical Position control
- ⑭ VARIABLE (CH-1 or sensitivity fine adjuster), PULL x 10:
Are the vertical sensitivity fine adjusters capable of continuously attenuating from each VOLTS/DIV range indication value to

[Vertical Block]

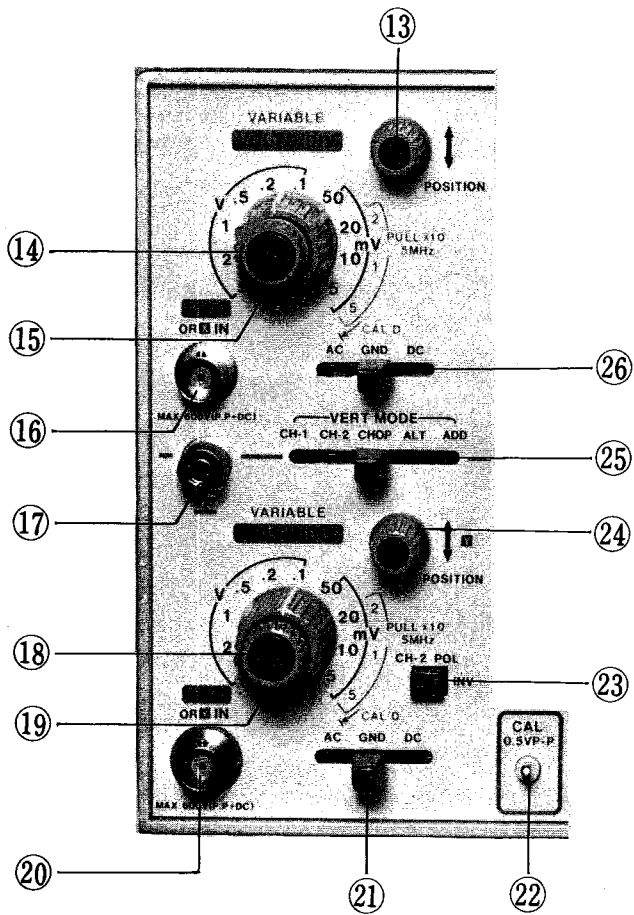

- ①⑤ VOLTS/DIV (CH-2 or **Y** sensitivity switch): This is a knob for switching the sensitivity of the input signal fed to CH-2 ②①. On X-Y operation, the knob functions to change the sensitivity of the Y-axis.
- ②① CH-2 or **Y** IN: This is an input plug for use with the CH-2 vertical amplifier and Y-axis (vertical axis) amplifier during X-Y operation.
- ②① AC-GND-DC (Alternating Current—Ground—Direct Current Switch), CH-2: Switches the coupling of the signal fed to the vertical axis input ②①. DC coupling is obtained on the DC position, on AC position the direct current component is blocked by a capacitor. The GND position grounds the input of the amplifiers and opens the input terminal ②①.
- ②② CAL 0.5V p-p (Calibration wave): Signal output terminal for amplitude and probe calibration. Frequency is 1 kHz. approx.



less than 1/2.5 of the value selected. In voltage measurements, the VARIABLE knob should be turned full clockwise to the CAL'D position. When the knob is pulled, the sensitivity is magnified by a factor of 10. In this case, noises increase and the frequency band is squeezed to a bandwidth of 5 MHz. When the super high sensitivity (500 μ V/div.) is not required, keep the knob pushed-in.

- ①⑤ VOLTS/DIV (CH-1 or **X** sensitivity switch): This is a knob for switching the sensitivity of the input signal fed to CH-1 ①⑥. On X-Y operation, the knob functions to change the sensitivity of the X-axis.
- ①⑥ CH-1 or **X** IN: This is an input plug for use with the CH-1 vertical amplifier and X-axis (horizontal axis) amplifier during X-Y operation.
- ①⑦ **⏏** Ground terminal
- ①⑧ VARIABLE (CH-2 or **Y** sensitivity fine adjuster), PULL x 10: The same as item ①④ above for CH-2.
- ②③ **⏏** CH-2 POL. **⏏** INV. (CH-2 Polarity inversion switch): Set at **⏏** (push-out) for normal operation. At INV. (inversion) **⏏** (push-in), the polarity of the signal applied to CH-2 will be inverted.
- ②④ **Y** **⬆** (Vertical position adjustment):
- ②⑤ VERT MODE: Determines the mode of display. CH-1; Only the input signal applied to CH-1 is displayed. CH-2; Only the input signal applied to CH-2 is displayed. CHOP (rapid switching display); For dual-trace display, when CHOP is selected, rectangular waveform of about 250 kHz is high-speed switched and dotted-line displayed regardless the A TIME (main sweep). ALT (alternate display); For dual-trace display, when ALT is selected, the CH-1 and CH-2 are alternatively switched for every sweep of the A TIME (main sweep). ADD. (Addition); The input signals of CH-1 and CH-2 are algebraically added and displayed. When the CH-2 polarity inversion switch ②③ is at INV., subtraction is accomplished.

- ②6 AC-GND-DC (Alternating Current—Ground—Direct Current Switch), CH-1:
The same as item ②1 above for CH-1.

4.4 Synchronizing Block

[Synchronizing Block]

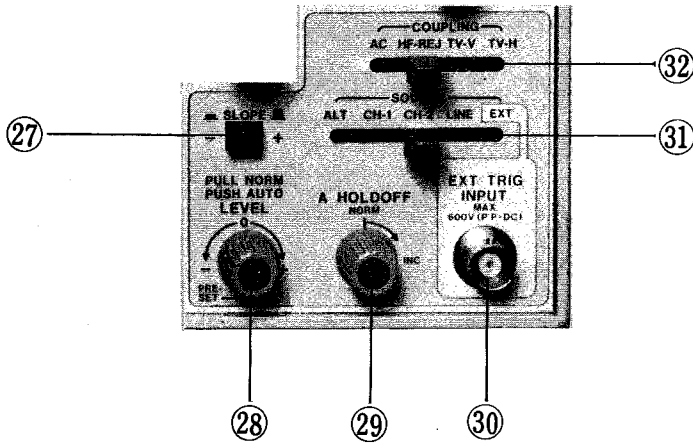

- ②7 **SLOPE** \pm , TV POL. (synchronization slope, TV polarity):
When triggered sweep is required with a positive slope of a waveform on the screen, select (+); and with a negative slope, select (-). You may select either one which is convenient.

- ②8 **LEVEL** $\overset{0}{-}$ $\overset{+}{+}$, PRESET (synchronization position adjustment), PULL NORM, PUSH AUTO:
Set the knob to a convenient position for the starting of triggered sweep of the A TIME (main sweep). In this case, when the setting value is out of changing portion of the observation waveform, the synchronization sweep stops.
When the trigger mode is set to the PULL NORM position, the waveform on the screen disappears. At the PUSH AUTO position, the trace will flow.
At the PRESET (full counter-clockwise at the notched position), the LEVEL is preset at the middle of the waveform.

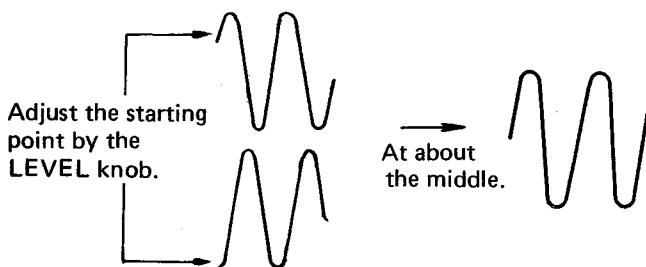

- ②9 **A HOLDOFF** (variable knob):
Adjusts holdoff (pause) time of the A TIME (main sweep). Pause time becomes longer when the knob is turned to the \curvearrowright INC direction, and the brightness of the display decreases.
Normally, the white mark of the knob is set at NORM position where notched at the middle.
When the pulse train is to be synchronized as shown in the figure below, the knob is turned to an appropriate position where the display stops still. (In this case, if the ③4 A VARIABLE is turned to keep the display still, the time measurement is not possible because the ③5 A TIME is in UNCAL. condition.)

Signal such as pulse train is intermittently repeated.

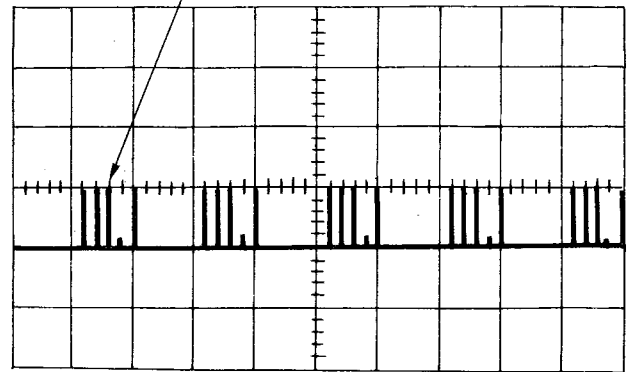

- ③0 **EXT. TRIG. INPUT**:
Is the input terminal for external synchronization signals. As the input amplifier is in DC coupling, the DC component should be eliminated by a capacitor (about 0.1 μ F), when the input AC signal is superposed on DC of more than ± 2 V. Further, care must be taken not to apply a voltage exceeding the maximum allowable input voltage, 600V (ACp-p + DC).
- ③1 **SOURCE**:
Selects the synchronization signal source as follows:
ALT:
Alternatively extracts the vertical input signals of the CH-1 and CH-2 for the synchronization. In this case, the ②5 VERT MODE must be set to ALT. When the VERT MODE is set to CH-1, CH-2, or ADD, synchronization is available by setting the SOURCE to ALT. (For the ADD, the synchronization is made with the CH-2.)
CH-1:
The vertical input signal of CH-1 is extracted for the synchronization.
CH-2:

The vertical input signal of CH-2 is extracted for the synchronization.

LINE trigger (power synchronization):

The power supply signal is used as the synchronization signal source of the A/B TIME.

EXT. TRIG. (external synchronization):

Is used to externally apply the synchronization signal.

32 COUPLING:

Selects coupling of synchronization signal as follows:

AC:

Is selected when synchronization is to be made with an AC signal of 2 Hz to 35 MHz. Normally, AC coupling is selected.

However, when synchronization is to be made with a signal of low frequency, lower than 30 Hz, the 28 LEVEL knob should be pulled to set to the PULL NORM position.

HF REJ:

For measurement of a waveform of less than 10 kHz, which includes noises and parasitic oscillation of signals higher than about 100 kHz, this HF REJ is used to eliminate the HF components to obtain a stable synchronization.

TV-H }
TV-V } Synch separation of TV picture signal:

When the COUPLING is set to one of these modes, synchronization is available from the composite picture signal of TV/VTR to get a stable display, because the similar synch separation circuit as in a TV set is active.

4.5 Sweep Block

[Sweep Block]

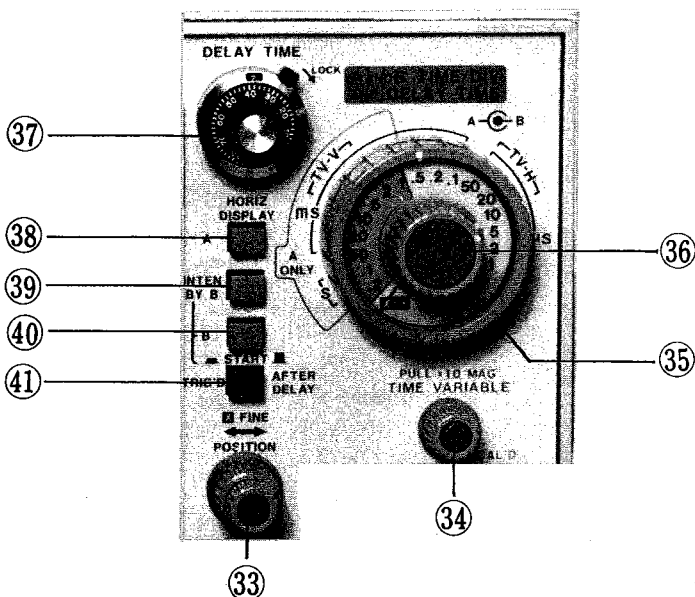

- 33 X↔ (Horizontal position adjustment):
Pattern moves to the right with clockwise rotation and to the left with counterclockwise rotation.

As fine and rough adjustments are available by the dual-knob, by turning the outer knob (FINE), fine adjustment is possible when the horizontal magnifier (MAG x 10) is used. On X-Y operation, adjust the horizontal position of the X-axis (CH-1) by this control.

- 34 TIME VARIABLE, PULL x 10 MAG.:

Makes continuously variable fine adjustment between ranges of the A TIME (main sweep). Normally, time measurement is made at the CAL'D position where the knob is turned fully clockwise.

When the knob is pulled, the trace is magnified by a factor of 10 to the horizontal direction.

- 35 A TIME/DIV (main sweep) time axis knob:

When the 38 A is selected, time measurement is made using this A TIME/DIV. In this case, the red 34 VARIABLE knob must be set at the CAL'D position turned fully clockwise. When the 39 INTEN BY B is selected, the time between the left end of the A TIME waveform and the left end of the B TIME intensified waveform is referred to as DELAY TIME, and this time is also measured using the A TIME/DIV. The scale value indicating the DELAY TIME equals the indication of the 37 DELAY TIME dial (see description of item 37).

- 36 B TIME/DIV (magnified sweep) time axis knob:

Using this knob, time measurement is made of a waveform magnified by the 40 B. VARIABLE knob is not provided for the B TIME.

- 37 DELAY TIME 10-rotation dial:

Sets the starting point (delay time) of the B TIME (delayed sweep) against the A TIME (main sweep).

Digits 1 through 10 displayed in a small window above the dial are precalibrated corresponding to the div. scale on the CRT. Scales 0 through 99 on the dial face correspond to subscales for single div., in a relationship of 10 = 0.1 div.

However, when the 41 B TRIG'D (Triggered delay) is pushed-in, the delay time does not continuously correspond to the dial, but it jumps to the next triggered point.

- 38 A (main sweep):

When the HORIZ DISPLAY switch is set to this position, the A TIME (main sweep: normal sweep) is selected.

③⑨ INTEN BY B:
This switch is used to intensity-mark the magnified B sweep portion against the A sweep trace. The portion is set by the ③⑦ DELAY TIME dial and the ③⑥ B TIME/DIV (magnified sweep) switch.

④① B (magnified sweep):
Displays the portion intensify-marked by the ③⑨ switch full in the screen. In this case, time measurement is made using the ③⑥ B TIME/DIV.

④① START / AFTER DELAY/TRIG'D:
The A sweep starts sweeping in synchronization with trigger signal such as of the input signal. In this case, there are two methods of starting the B sweep; one is the continuous delayed sweep, and the other is trigger delayed sweep.

Normally, the continuous delayed sweep is used to make a magnified display, where the START button is pulled out, i.e., AFTER DELAY, and the B sweep is started immediately after the delay time set by the ③⑦ DELAY TIME dial. When this method is used, the portion to be magnified can be continuously moved and be freely set.

The figures below illustrated the abovedescribed.

Continuous delayed sweep:

Set the ④① START to pushed-out position (general delayed magnification) and select the AFTER DELAY.

Get synchronization with the observation waveform using the ③⑧ A sweep.

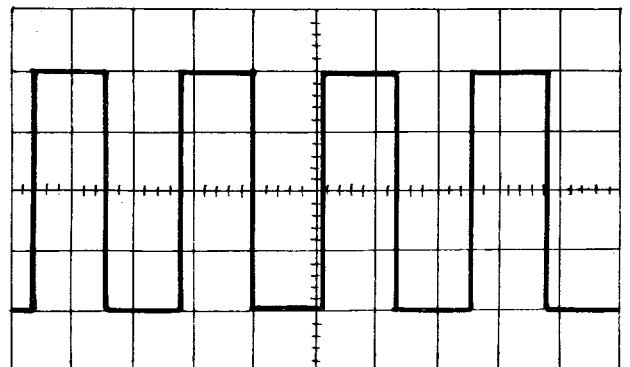

Intensity modulation portion

This position can be continuously selectable by the ③⑦ DELAY TIME and ③⑥ B TIME knobs.

Set the portion to be magnified (intensity modulation portion) by the ③⑨ A INTEN BY B.

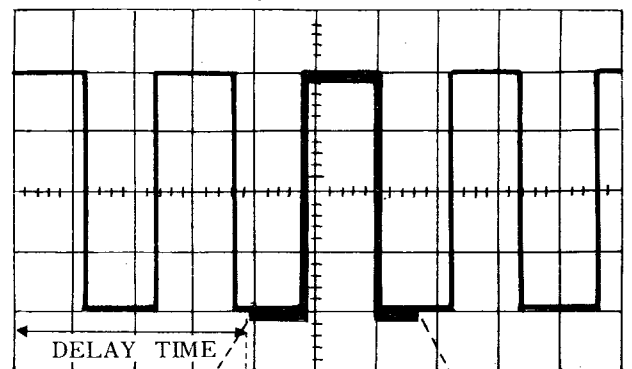

The portion is magnified full in the screen when the ④① B sweep is selected.

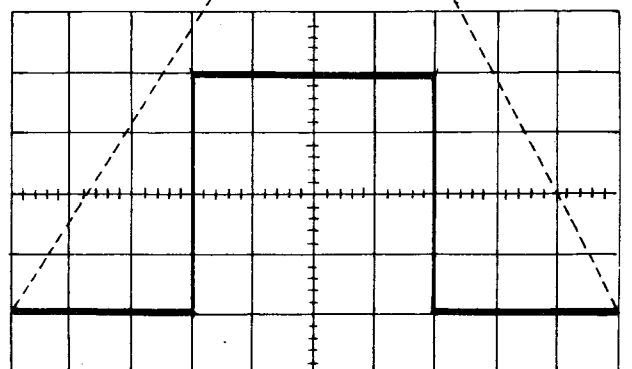

On the other hand, the ④① B TRIG'D is used, when magnification ratio is to be increased, or synchronization is to be made with a special pulse train.

When the ④① B TRIG'D is selected, at the ③⑨ INTEN BY B, the intensity modulation point does

Trigger delayed sweep:

Set the ④① B TRIG'D to pushed-in position (special delayed magnification).

③⑧ A sweep

The starting point of the intensity modulation is synchronized with the rise or fall portion by turning the ③⑦ DELAY TIME knob.

③⑨ A INTEN BY B

Triggering of the B sweep is made by the pulse just after held by the DELAY TIME.

④① B sweep

As the B sweep is also being triggered by the input signal, jitter is decreased compared with the continuous delayed sweep.

not continuously follow the ③⑦ DELAY TIME dial, but jumps to the trigger point in sequence. At the ④① B, the display waveform does not continuously move, and a repetitive waveform is kept still without change.

For such a pulse train as illustrated, select a synchronization point using the ②⑨ A HOLDOFF knob.

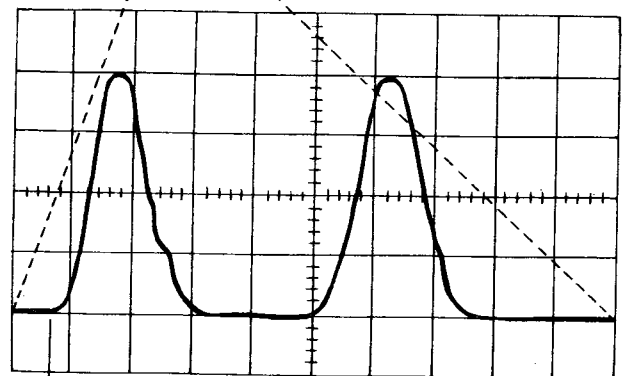
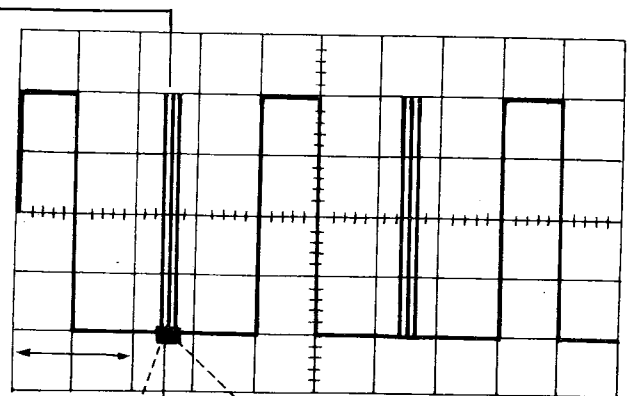
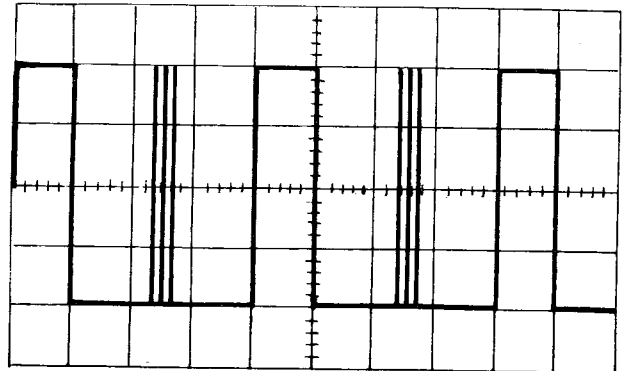

4.6 Rear Panel

④② CH-1 OUTPUT:

The input signal applied to the CH-1 is always available on this BNC terminal, via the vertical CH-1 preamplifier and the buffer amplifier of the oscilloscope.

With the 50-ohm termination, the output of about 100 mVp-p per a single div. in ampli-

tude of the screen is available. The CH-1 OUTPUT terminal will be described in section 6.8.

④③ Z AXIS INPUT:

The intensity modulation signal to be applied to the display waveform is input to this terminal. This Z AXIS INPUT terminal will be described in detail in section 7.14.

5. BASIC OPERATIONS

This section describes the basic operations to display the calibration waveform (22 CAL 0.5 Vp-p) on the oscilloscope.

5.1 How to Display Trace Line

When the instrument is to be used for the first

time, set the switches and knobs as indicated below, and turn on the power to display the trace line.

The same setting and the procedure as indicated can be used to check if the instrument correctly operates.

Initial settings of the elements:

Name of element	Basic setting
④ FUSE	(100V rating) 1A, time lag type
⑤ Power cord	After the initial setting are complete, apply the power of the rating voltage.
⑥ POWER <input type="checkbox"/> / <input checked="" type="checkbox"/> ON/OFF	Push on the power switch, after the initial settings.
⑧ ILLUM	Full clockwise.
⑨ ROTATION	Adjust if the trace line is not horizontal.
⑩ FOCUS	Set the white point at the 12 o'clock direction.
⑪ INTEN	Set the white point at the 2 o'clock direction.
⑫ (CH-1)	Set the white point at the 12 o'clock direction.
⑭ VARIABLE (CH-1) PULL x 10	Full clockwise to CAL'D position (notched). Push in.
⑮ VOLTS/DIV (CH-1)	0.1V/div.
⑯ CH-1 IN	Open
⑰ VARIABLE (CH-2) PULL x 10	Full clockwise to CAL'D position (notched). Push in.
⑱ VOLTS/DIV (CH-2)	0.1V/div.
⑳ CH-2 IN	Connect the probe LP-16AX (x1).
㉑ AC-GND-DC (CH-2)	DC
㉒ CAL 0.5Vp-p	Touch the probe tip of the CH-2 input.
㉓ CH-2 POL.	<input checked="" type="checkbox"/> Push out (NORM).
㉔ (CH-2)	Set the white point at the 12 o'clock direction.
㉕ VERT MODE	ALT
㉖ AC-GND-DC (CH-1)	DC

- ②7 SLOPE
- ②8 LEVEL
- PULL NORM/PUSH AUTO
- ②9 A HOLDOFF
- ③0 EXT TRIG INPUT
- ③1 SOURCE
- ③2 COUPLING
- ③3 ↔ FINE

- ③4 TIME VARIABLE
- PULL x 10 MAG
- ③5 A TIME/DIV
- ③6 B TIME/DIV
- ③7 DELAY TIME

- ③8 A
- ③9 INTEN BY B
- ④0 B
- ④1 START

HORIZ
DISPLAY

■ +

Set the white point full counter-clockwise to PRESET position (notched).

Push in (AUTO).

Full counterclockwise to NORM position (notched).

Open

CH-2

AC

Set both the white points of the adjusters of the dual-knob at the 12 o'clock direction.

Full clockwise at CAL'D position (notched).

Push in.

0.5 ms/div.

50 μs/div.

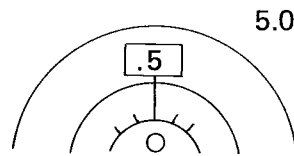

Push in ■ ③9 INTEN BY B

■ AFTER DELAY

After the above settings, connect the power cord plug to the source of the specified rating. Then, push in the ⑥ POWER switch; after the ⑦ lamp is lighted showing the power on, in 10 seconds square waveform and the trace line are displayed on the screen as shown in the figure right.

Further, adjust the ⑩ FOCUS to get a sharper trace line. When the horizontal trace line is not in parallel with the horizontal graticule, correct the decline adjusting the ⑨ ROTATION screw using a screwdriver.

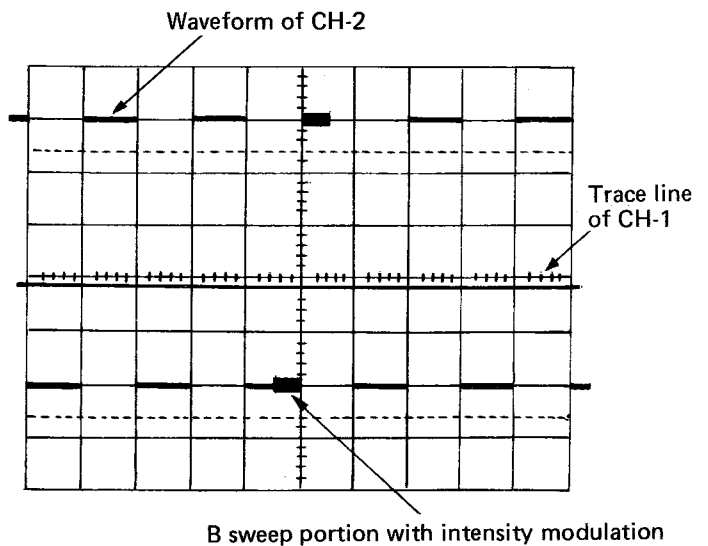

5.2 Gain Checking by Calibration Waveform

The signal available from the CAL is calibrated as the one with 0.5 V_{p-p}, square wave, and about 1 kHz in frequency. Thus, it can be used not only for the calibration of the vertical axis gain, but also for rough calibration of the time axis.

As shown in the above table of the initial settings, when the 0.5 V_{p-p} signal of the CAL terminal is applied to the 0.1V/div. range using the x1 probe, the vertical amplitude of 5 div. is displayed. The CH-1 is also applied with the CAL signal.

Further as the signal is symmetrical square waveform of 1 kHz in frequency, the upper and lower flat portions of the square wave are displayed in every single division when the 0.5 ms/div. is selected.

By the above described operation, the correct operation of the oscilloscope can be checked.

5.3 How To Use a Low-capacitance/Direct Probe

The LP-16BX Probe is an extremely well designed, high-performance probe equipped with X1 and X10 switching functions.

5.3.1 Specifications

Maximum input voltage:
250V_{rms} or 600V DC

(1) At X10

Input resistance: 10M Ω
Input Capacitance: 25pF or less
Correction range: Oscilloscope with input capacitance 20 – 40pF

Attenuation factor: 1/10 \pm 2%
Frequency range: DC – 40 MHz

(2) At X1

Input resistance: 1M Ω
Input capacitance: 250pF or less
Frequency range: DC – 5MHz

5.3.2 Operation of low capacitance probe.

Turn the knob and grip to the required position to set the arrow to X1 or X10. The knob and grip may be turned in any direction.

(1) Measurement at X10

The probe exhibits high resistance and low capacity at X10. However, the input voltage is attenuated to 1/10 and, therefore, this must be accounted for in voltage measurement.

Measured voltage = Sensitivity of oscilloscope V/div X screen amplitude div X10

At X10, it is necessary to correct the pulse characteristic by adjusting the capacitor in the probe for flat top of the square wave calibration voltage.

(2) Measurement at X1

This probe maintains high sensitivity in the X1 position so that it may be used directly with the oscilloscope. However, the input capacity is large approx. 250pF, and it is necessary to take this into account when making measurements.

(3) How to use the straight tip

For the use of straight-tip, please detach the retractable hook tip as shown in illustration.

The straight tip is extremely convenient when testing points on printed circuit boards.

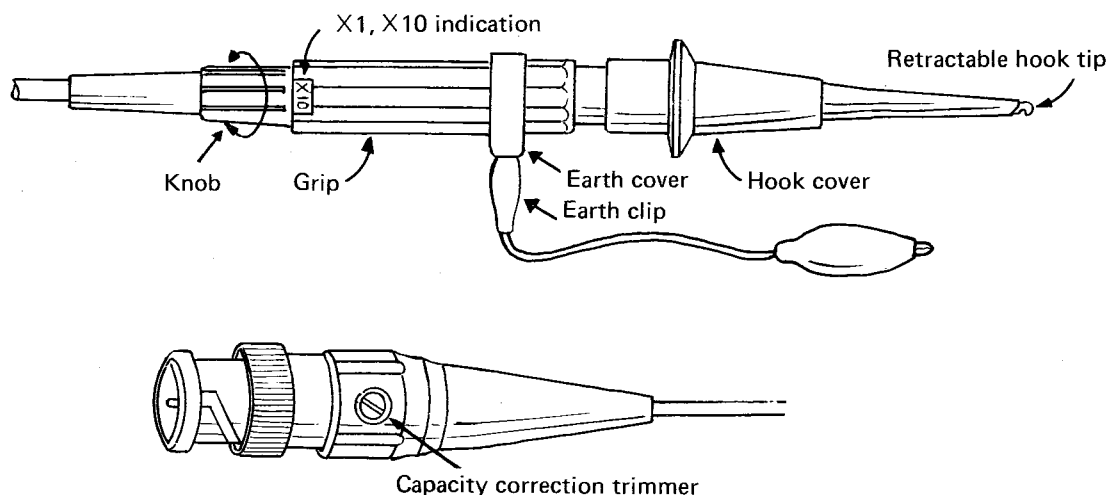

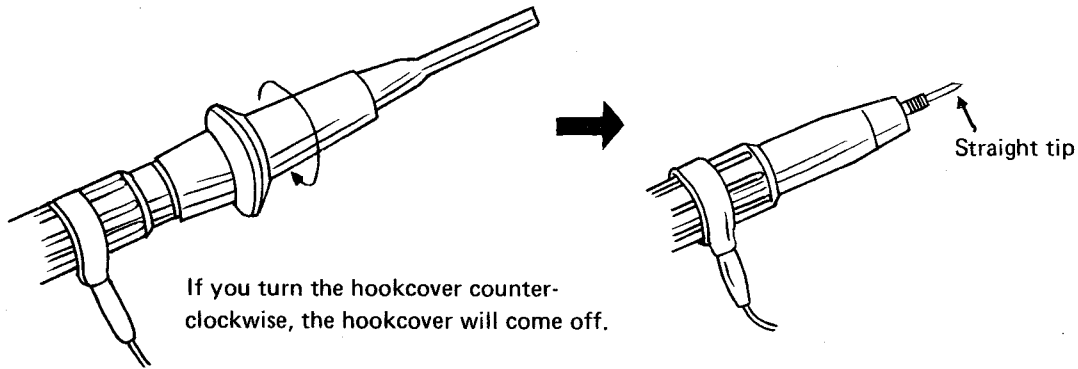

5.3.3 Adjustment of probe

To adjust the probe, connect as shown below and turn the variable capacitor in the probe connector using a small screw driver, to provide proper square wave compensation.

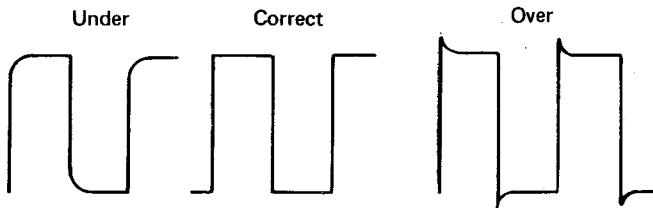

5.4 Note on Direct Connection and Use of Probe

For small signal measurement of a high impedance signal source, as measurement error may be introduced by the noises induced to the input cable and by the influence of parallel capacitance, use of a lead wire should be avoided and a shielded wire such as coaxial cable must be used. The length of the shielded wire should be as short as possible. For a high impedance circuit, attention should be paid to the load effect in which the sum of the input capacitance of the oscilloscope and the distribution capacitance of the shielded wire influences the signal source. When the influence of the parallel capacitance on the signal source is not neglectable, use the X10 low-capacity probe.

Note on Use of Low-capacitance Probe

To avoid many ill effects by direct connection, use a low-capacitance probe (X10) as much as possible. When this probe is used, input impedance is $10M\Omega$, 25pF, thus making it possible to reduce the loading effects upon the signal source to a great extent. However, when the probe is used at X10, the input signal is attenuated to 1/10, this must be taken into account in all measurements.

5.5 Ground Connection

For ground connection, use the shortest possible wire as described in Section 5.4. When using a probe, connect to a ground point close to the signal source, and use the probe ground wire.

5.6 Dual Trace Measurement

Two vertical axis input circuits are provided in this instrument, and the waveforms of the two input signals are alternately shown on the screen by means of an electronic switch. However, since there is only one horizontal sweep circuit, it is not possible to have two synchronized or locked-in waveforms of two unrelated, independent input signals simultaneously on the screen. Two different methods are available for alternately switching of two signals making use of the electronic switch.

5.6.1 ALT.

ALT. (Alternation) serves to show two signals, CH-1 and CH-2, alternately sweep by sweep.

Flicker increases at a low speed sweep, slower than 0.5 ms/div., so that measurement is inconvenient. In such a case, use the CHOP mode.

5.6.2 CHOP

CHOP performs switching between two signals, CH-1 and CH-2, in high speed (about 250 kHz) and displays the two waveforms on the screen so that both waveforms look continuous.

This mode is mainly used for a slow speed sweep. When it is used for a higher speed sweep of more than 0.5 ms/div., the trace may be displayed as a dotted line.

5.7 Synchronization to Waveforms

The most important factor in operating the oscilloscope is to lock and display waveforms properly before measuring them.

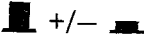
(1) Method of synchronization sweep	Auto sweep (AUTO) Sync. sweep (NORM)	Ⓒ Push Ⓒ Pull
(2) Selection of synchronization signal source (SOURCE)	Internal CH-1/-2 alternative Internal Power signal External	CH-1 ALT CH-2 LINE EXT } Ⓒ
(3) Coupling of synchronization signal (COUPLING)	AC coupling HF elimination TV-V extraction TV-H extraction	AC HF-REJ TV-V TV-H } Ⓒ
(4) Selection of synchronization position (LEVEL, SLOPE, and HOLDOFF)	Variable of start position (LEVEL) Slope of waveform (SLOPE) Timing of synchronization (A HOLDOFF)	Ⓒ knob Ⓒ  +/- Ⓒ knob

To make the most use of the synchronizing capacity of this instrument, a proper method of operation is described below, taking waveforms as an example.

To obtain correct synchronization, the procedure of items (1) through (4) shown in the table above must be followed. The table shows the synchronization of the A TIME (main sweep). The synchronization of the B TIME (magnified sweep) is described in section 5.7.5.

By appropriate selections and adjustments of the abovementioned control knobs and switches, a stable waveform can be displayed.

For measurement of simple waveforms, set as follows: (1) TRIG MODE to Ⓒ AUTO, (2) SOURCE to Ⓒ CH-1 or CH-2, (3) COUPLING to Ⓒ AC, (4) LEVEL to Ⓒ PRESET. The SLOPE Ⓒ can be either + or -, and set the white point of the A HOLDOFF at the 12 o'clock direction (NORM).

5.7.1 Mode of synchronizing sweep

Generally, for waveforms which have a frequency of 50 Hz or more and are not complex, use AUTO synchronization. At AUTO synchronization, the sweep circuit is automatically placed in the free-run state when the aforementioned trigger pulse is not produced and a horizontal trace is displayed irrespective of A sweep time set by the knob Ⓒ.

To remove waveforms on the screen when no input signal is applied or the trigger level is not correct, PULL a knob Ⓒ to NORM.

5.7.2 Selection of synchronizing signal source

Internal:

Normally, synchronization is made by internal signal. For the CH-1 input, the Ⓒ SOURCE is set to CH-1; and for the CH-2 input, it is set to CH-2.

When the CH-1 waveform is displayed by setting the Ⓒ CH-1, and the synchronization signal source is assigned by setting the Ⓒ CH-2 to apply the synchronization signal to CH-2, the synchronization is available. Of course, the CH-2 waveform can be displayed by setting the ALT/CHOP.

In a dual-trace ALT display, synchronization is available by getting the synchronization signal from either one of CH-1 and CH-2 which are applied with signals having a synchronized relationship. However, by selecting the Ⓒ ALT, the both will synchronize though there is no synchronized relationship between the two signals. The Ⓒ LINE synchronization signal can be used for observations of the rectifier/filter circuit. Also, when the power frequency is the same with the vertical synchronization frequency, e.g., 60 Hz, with a TV set of power non-synchronization system, the LINE synchronization signal can be used to determine if the observation signal is of synchronization pulses or of the power ripple, by observing stable or flow of the trace display.

The CH-1 and CH-2 waveforms being observed are in a synchronized relationship, if the frequency of the both is the same, a stable synchronization is available by selecting either signal as the synchronization signal. When the frequencies are different, by selecting the lower one as the synchronization signal, the traces of the both channels will be stable.

5.7.3 Coupling of synchronizing signals

Even when the synchronizing signal is actuating the synchronizing sweep circuit, it is possible to have unstable synchronization of the waveforms being observed. In this case, select the COUPLING switches as follows so that proper synchronization is obtained.

Normal waveform observation

Set switch ③② at AC. At this point, the synchronizing signal is connected to the synchronizing sweep circuit through a capacitor, thus eliminating the DC component and provides stable synchronization over the whole bandwidth of 2 Hz or higher. AC coupling takes place with synchronization that is not affected by a change in the DC component of the waveforms being observed.

Waveform signal superposed with noise

When synchronization is unstable, though the synchronization sweep circuit is operating, due to the synchronization signal superposed with noise such as of high frequency, the HF REJ function should be selected.

The synchronization signal goes through the low pass filter and the unnecessary high frequency components higher than 100 kHz are removed, so that a stable synchronization is available.

T.V. (Video) composite waveforms

In T.V. video waveforms, horizontal and vertical synchronizing components are combined. It is, therefore, very difficult to apply synchronization to the horizontal component or vertical component.

In this case, the horizontal and vertical synchronization signals are automatically separated from the composite picture signal, and thus a stable synchronization is available. The TV-V signal synchronizes with the vertical pulses, and the TV-H signal synchronizes with the horizontal pulses.

Set the SLOPE switch to + or - depending on polarity of video composite signal.

5.7.4 Selection of synchronization position

In a triggered sweep type oscilloscope, it is possible to adjust the position or timing of starting of the waveform so that stable trigger (starting) pulses may be obtained.

Adjustment of starting (trigger) position

To move the synchronization position to the section where changing waveforms are stable, adjust LEVEL knob ②⑧ as shown below.

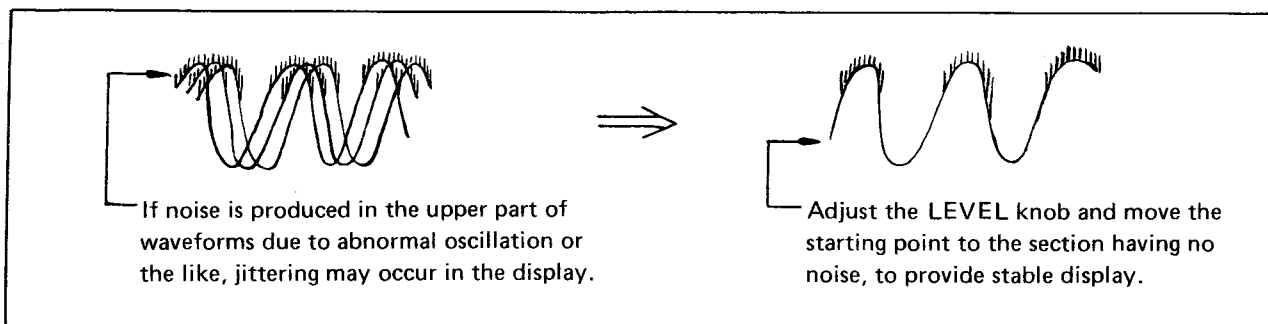
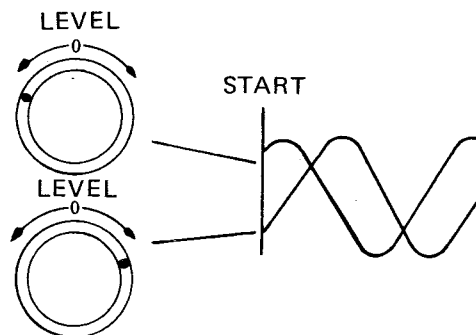

For a simple signal which is not extremely asymmetrical, set the knob to the PRESET position; the synchronization will be made at about the middle of the waveform.

Selection of waveform slope (SLOPE +/-)
For example, in case of a square wave,

especially when jittering is taking place in the fall portion, stable synchronization can be obtained if starting is performed in the rise portion. SLOPE switch (27) functions to select the slope (rise or fall section) of the starting (trigger) point of this synchronizing signal waveform.

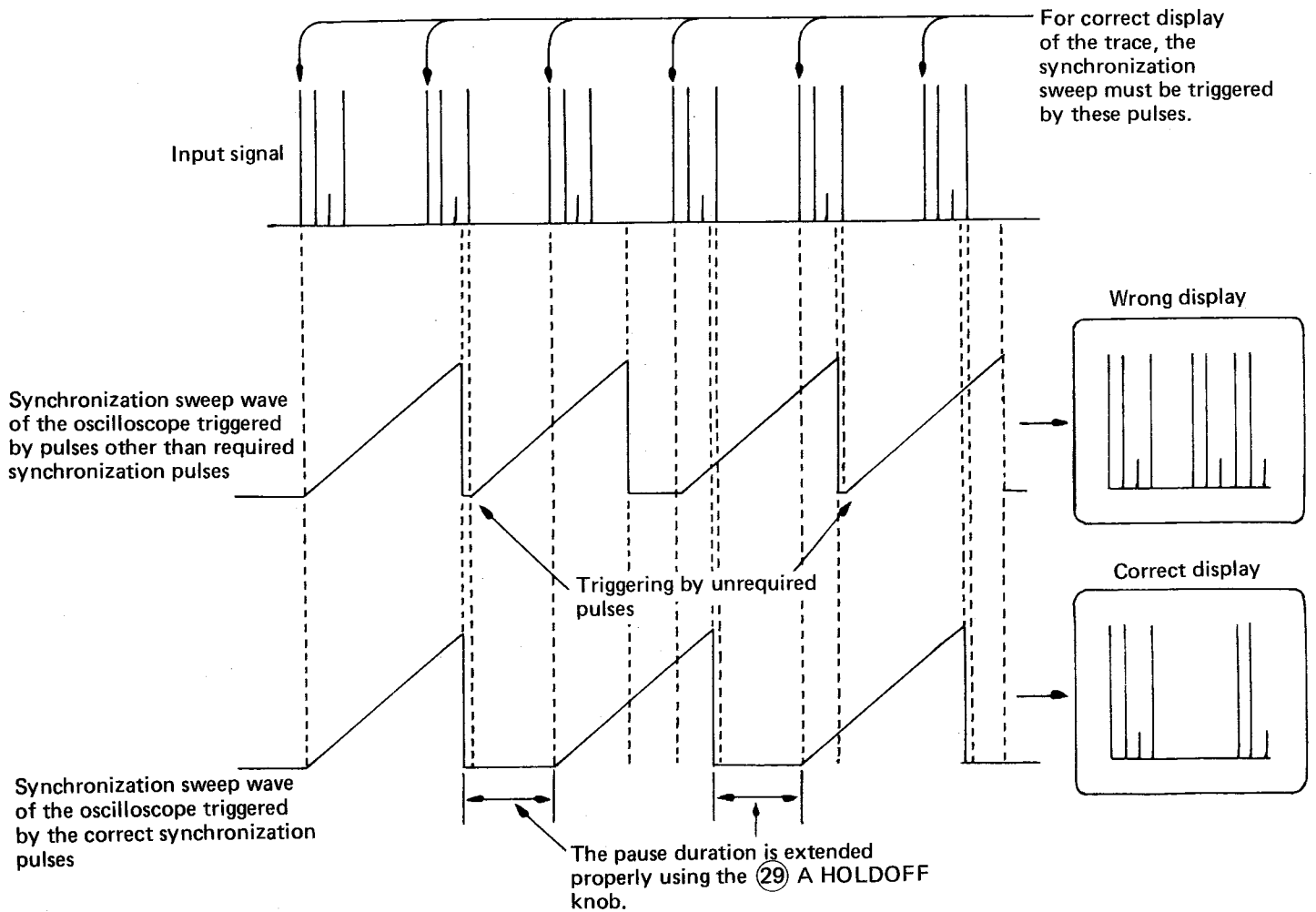
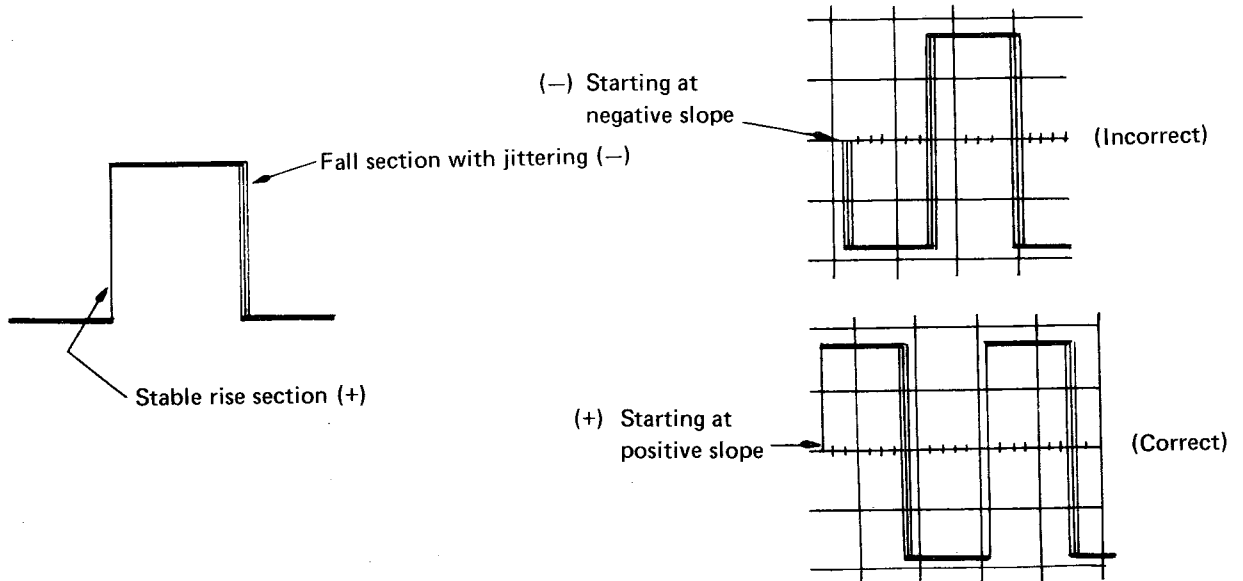

Synchronization for intermittent pulse train (A HOLDOFF)

For observation of signals such as intermittently repeated pulse train, the waveform may not be correctly displayed though the waveform looks synchronized. In such a case, by making the (29) A HOLDOFF knob variable for adjusting the timing, the trace can be displayed properly. In that the pause duration of the synchronization sweep is made variable, and triggering by pulses other than the required synchronization pulses is prevented.

5.7.5 B TIME synchronization

Normally, the sweep of the B TIME is driven immediately after the delay time (■ START AFTER DELAY) set by the (37) DELAY TIME dial, and magnified display is made. Magnification jitter increases when the magnification ratio is increased.

Thus there is a method for applying synchronization (■ TRIG'D) to the input signal, which is called the TRIGGERED delay.

In that, triggering of the B TIME is suspended until the position is reached indicated by the (37) DELAY TIME dial, and the synchronization sweep is driven by the first pulse of the triggering pulses applied to the B TIME. The signal source and coupling for the synchronization signal of the B TIME are the common with that of the A TIME.

5.8 CH-1 OUTPUT

The input signal applied to CH-1 is always available from this BNC terminal, through the preamplifier of the oscilloscope's vertical axis CH-1 and the buffer amplifier.

Output impedance: 50 Ω

Output voltage: approx. 100 mV per 1 div. amplitude (at the 50- Ω termination)

Frequency response: (DC) DC to 40 MHz, -3 dB
(AC) 10Hz to 40MHz, -3 dB

Because of the above specification, the output is proportional to the amplitude on the screen.

For example, 5 div. is:

$$5 \text{ div.} \times 100 \text{ mVp-p/div.} = 500 \text{ mVp-p}$$

Thus when an appropriate waveform is displayed on the screen, roughly a constant output is available. Therefore, by connecting a frequency counter to this terminal, frequency measurement is available in parallel with the waveform observation, without adjusting the sensitivity of the counter.

Further, by using the PULL X10 (14) and (18), the maximum 500 μ Vp-p/div. of high sensitivity is available, so that the super high sensitivity counter can be realized.

On the one hand, the CH-1 OUTPUT terminal can be used as a high sensitivity and wideband amplifier.

6. MEASUREMENTS

6.1 AC Peak Voltage

When it is desired to determine only the AC voltage component of the signal being measured, set AC-GND-DC switch ⑳ or ㉔ at AC and, from the amplitude on the screen at this time, calculate the peak voltage as follows:

Measurement using a lead wire

$$\text{Peak voltage (Vp-p)} = \text{Value indicated at VOLTS/DIV} \times \text{amplitude (div.)} \times \frac{1}{\text{MAG}}$$

Measurement using a X10 probe

$$\text{Peak voltage (Vp-p)} = \text{Value indicated at VOLTS/DIV} \times \text{amplitude (div.)} \times 10 \times \frac{1}{\text{MAG}}$$

However, the magnifiers act as:

$$\begin{cases} \text{PULL:} & \text{factor of 10} \\ \text{PUSH:} & \text{factor of 1} \end{cases}$$

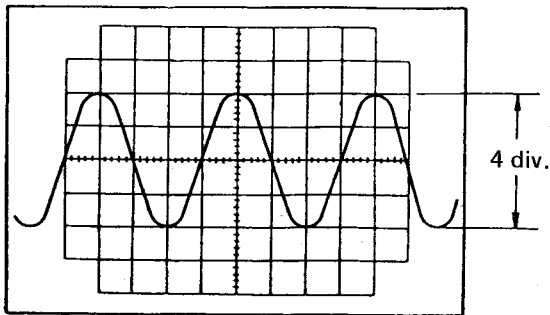

As shown above, the voltage of the signal being measured is calculated as follows:

If VOLTS/DIV = 0.05V/div. (setting MAG off),
Peak voltage when a lead wire is connected directly
= 0.05V/div. X 4 div. = 0.2Vp-p

Peak voltage when using a X 10 probe = 0.05V/div.
X 4 div. X 10 = 2Vp-p

Notes: When measuring a voltage, be sure to turn the VARIABLE knobs ⑭ and ⑰ fully clockwise to CAL'D.

6.2 DC Voltage

Use AUTO sweep, set AC-GND-DC switch ⑳ or ㉔ at GND. The trace (bright line) should show 0V. Set the trace to a position for easy measurement on the screen. Next, set the AC-GND-DC switch at DC and read the shift of the trace on the screen.

6.3 DC + AC Peak Voltage

Make measurement using the "DC" and the "GND" as in the case of the measurement of DC voltage. If the range indicated at the VOLTS/DIV is 0.1V/div., the voltage of the signal being measured is obtained as shown below.

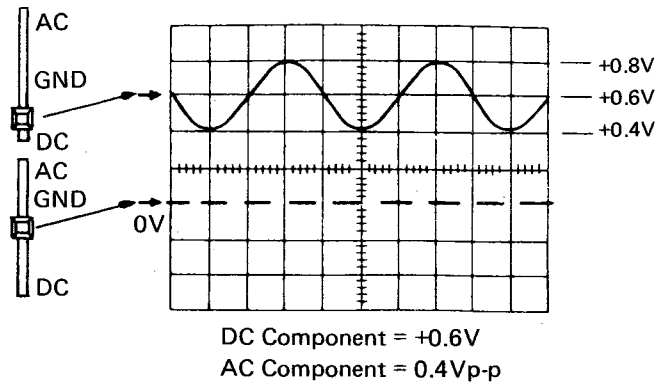

6.4 Time Interval Measurement

The time interval T is calculated as follows:

$$\text{Time T (sec)} = \text{Value indicated at TIME/DIV} \times \text{Interval on the screen} \times \text{Reciprocal of magnification of the magnifier}$$

The reciprocal of magnification of the magnifier is 1 when not magnified and 0.1 when magnified. The time interval T in the figure is calculated as follows:

$$\text{TIME/DIV} = 0.5 \text{ (0.5 ms/div.)}$$

When the magnifier is X 1, (PUSH)

$$T = 0.5 \text{ ms/div.} \times 3 \text{ div.} \times 1 = 1.5 \text{ msec}$$

When the magnifier is X 10 (PULL)

$$T = 0.5 \text{ ms/div.} \times 3 \text{ div.} \times 0.1 = 0.15 \text{ msec}$$

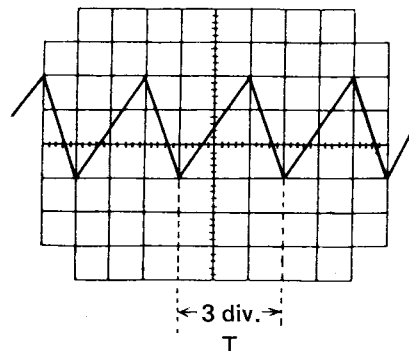

6.5 Frequency Measurement

The time of 1 period, T , is measured as given in the Section 6.4 above, and its reciprocal is the frequency F .

$$\text{Frequency } F \text{ (Hz)} = \frac{1}{T \text{ (seconds)}}$$

$$= \frac{1}{\text{Value indicated at TIME/DIV} \times \text{interval of 1 period on the screen} \times \text{reciprocal of magnification of the magnifier}}$$

For example, in the figure as shown below.

TIME/DIV: 0.5 ms/div.

Magnifier (MAG): X 1

Then, $T = 0.5 \text{ ms/div.} \times 4 \text{ div.} \times 1 = 2 \text{ msec}$

$$\text{Frequency } F \text{ (Hz)} = \frac{1}{T \text{ (sec.)}} = \frac{1}{2 \times 10^{-3}} = 500 \text{ Hz}$$

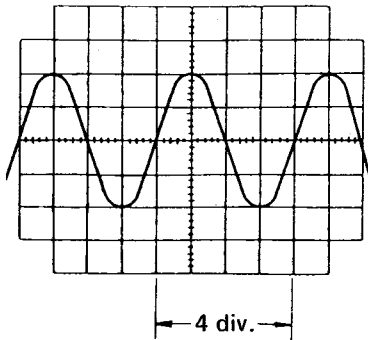

6.6 Rise Time of Pulse

6.6.1 Measurement by A sweep only

When measuring the rise time of a pulse by A sweep (main sweep), the X 10 horizontal magnifier 34 is used. Before measuring the rise time of a pulse, proper use of the magnifier will be described.

- (1) Place the portion being observed on the center of the scale by means of the \leftrightarrow knob.

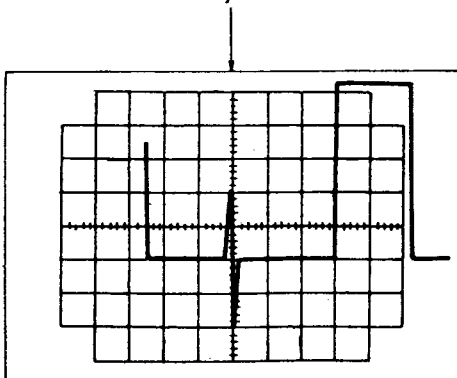

- (2) 10 times magnification to both sides.

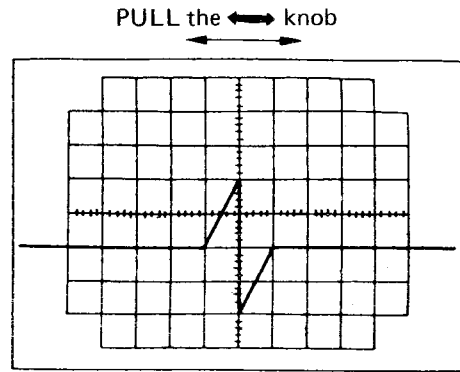

As mentioned above, the magnifier is used for detailed observation of a portion of a waveform. This is especially convenient when the enlargement of a portion of a waveform, away from its sync. sweep starting point, is desired.

Rise Time of Pulse

(Step 1)

SLOP 27: \blacktriangleleft (Push)

MAG. 34: \blacksquare X 1 (Push)

Set TIME/DIV 35 so that the leading edge of the pulse is caught on the screen. Position the VARIABLE 34 (red knob) to the end of its clockwise rotation.

(Step 2)

Align the flat portions of the pulse at the 0 and 100 scales of the % graticule.

(Step 3)

Place the leading edge of the pulse on the center line of the scale by means of the horizontal positioning knob.

(Step 4)

Make certain the MAGNIFIER is set at X 10 (PULL) calculation of rise time

$$T_r = (\text{TIME/DIV range}) \times (\text{Horizontal interval on the screen, div.}) \times (\text{Magnification rate, } 1/10)$$

Example

$$T_r = 2 \mu\text{s/div.} \times 2.9 \text{ div.} \times 1/10 = 0.58 \mu\text{s}$$

6.6.2 Measurement by B sweep (delayed sweep)

Magnification of a small portion is limited to a factor of 10, when only the above-mentioned MAG x 10 and the A sweep are used.

However, by using the B sweep, magnification is available up to the limit of the magnified jitter 10,000:1 of the instrument itself.

(Step 1)

After setting knobs and switches according to the description of section 5.1, apply the signal to the ①⑥ CH-1 input terminal.

(Step 2)

Push in \blacksquare the ③⑧ A sweep switch. Adjust the ③⑤ A TIME/DIV to display the portion to be observed on the screen. Then, if necessary, turn the ②⑧ LEVEL knob from the PRESET position to the clockwise direction and adjust to obtain a stable waveform display.

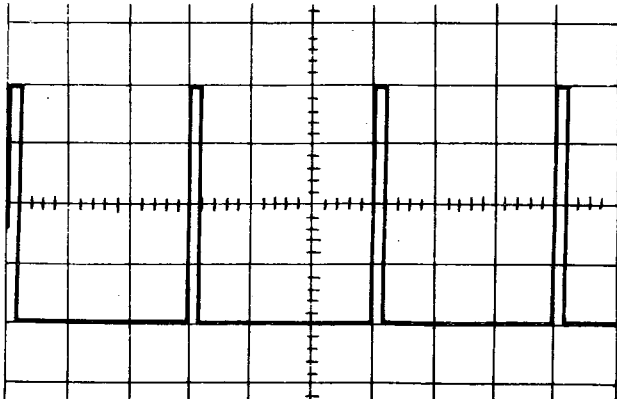

(Step 3)

Push in \blacksquare the ③⑨ A INTEN BY B. The intensity-modulated portion indicates the B sweep by delayed start. (However, the figure below shows the continuous delayed sweep by setting the ④① START to \blacksquare AFTER DELAY.)

In the figure,
A TIME/DIV = 0.5 ms/div.
B TIME/DIV = 50 μ s/div.

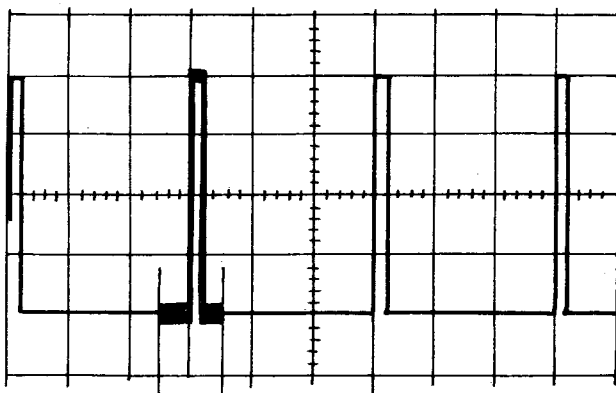

$T_D = 2.5 \text{ div.}$
This width should be set by an appropriate range turning the ③⑥ B TIME/DIV more to the clockwise direction than the ③⑤ A TIME/DIV. The position is set by the ③⑦ DELAY TIME.

Delay time of B sweep $T_D = 0.5 \text{ ms/div.} \times 2.5 \text{ div.} = 1.25 \text{ ms}$

(Step 4)

By pushing in \blacksquare the ④① B, the intensity modulation waveform indicated by the (Step 3) above is enlarged and displayed on the screen.

$Tr = 50 \mu\text{s/div.} \times 0.5 \text{ div.}$
 $= 25 \mu\text{s}$

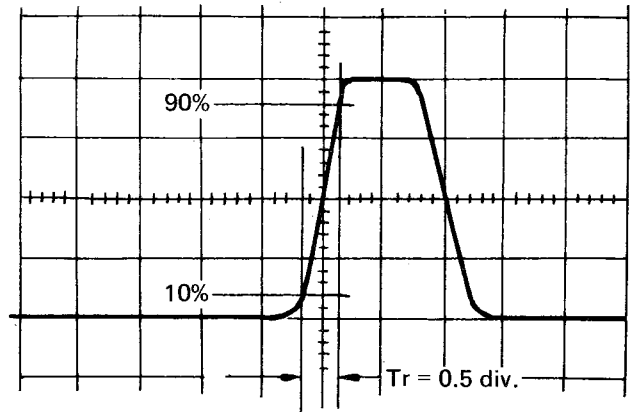

6.6.3 On Maximum sweep, 0.2 μ s/div., for both A and B [LBO-524L]

The limit is displayed using the MAGNIFIER at the X10 position. Here, the rise time of the LBO-524L must also be taken into consideration.

HORIZ. DISPLAY ③⑧ : A
A/B TIME/DIV ③⑤, ③⑥ : 0.2 μ s/div.
MAG. X1/X10 ③④ : X10

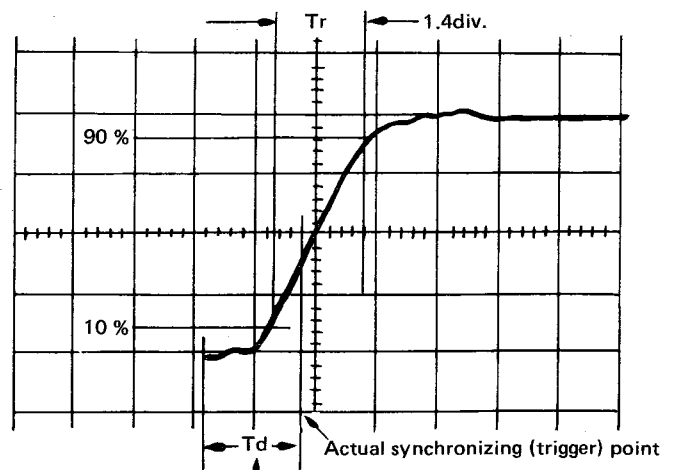

By the signal delay line of the vertical axis, the waveform before synchronization (trigger) is displayed.

T_a ; Rise time of the LBO-524L $\approx 0.35/40\text{MHz} = 0.009 \mu\text{s} = 9\text{ns}$

T_r ; Rise time observed on the screen
 $T_r = 0.2 \mu\text{s/div.} \times 1.4 \text{ div.} \times 1/10 = 28\text{ns}$

T_i ; True rise time of a pulse being measured

Thus, in the above example,

$$T_i = \sqrt{T_r^2 - T_a^2} = \sqrt{(28 \times 10^{-9})^2 - (9 \times 10^{-9})^2} = 26.5\text{ns}$$

6.7 Phase Difference between Two Signals

To measure a phase difference between two signals of the same frequency, the dual trace display system can be utilized up to the upper limit frequency of the amplifier.

First, position both signals on the center line of the scale, e.g. just 4 div., as shown in the following figure by means of the VARIABLE and horizontal positioning knobs.

Next, set the distance where the center of the waveform of the base channel intersects with the center of the scale to 8 div. horizontally.

If difficulty is encountered in properly displaying the phase difference as shown in the following figure because it (phase difference) is too large, use the polarity inversion switch of CH-2 (23) and move the phase by 180° beforehand, and then display the phase difference. After that, this 180° should be taken into account.

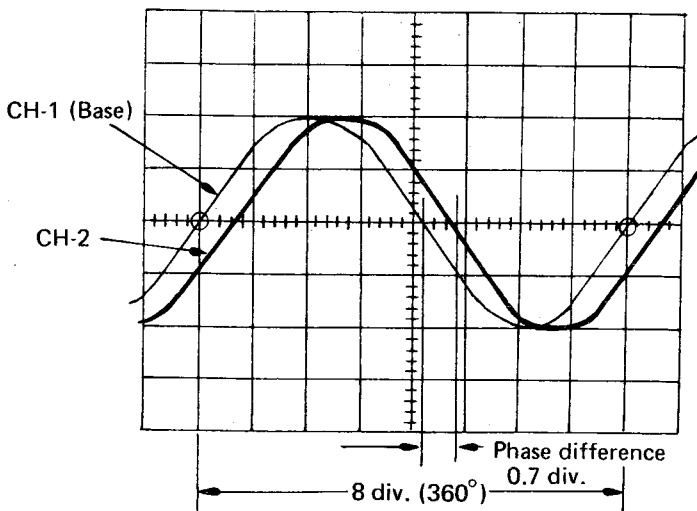

As shown in the above figure, set 1 cycle, 360° to 8 div. Then,

$$\frac{360^\circ}{8 \text{ div.}} = 45^\circ/\text{div.}$$

Accordingly, the phase difference in the above example can be calculated as follows:

Horizontal distance on the screen: 0.7 div.
 Phase difference = 45°/div. X 0.7 div. = 31.5°

If the portion of the phase difference is much smaller, use the MAGNIFIER at the X 10 position in the above setting. At this time, 360° is displayed in 8 div. X 10.

Then,

$$\frac{360^\circ}{8 \text{ div.} \times 10} = 4.5^\circ/\text{div.} \quad (0.2 \text{ div.} = 9^\circ)$$

6.8 Measurement of Phase Difference by X-Y Operation

The phase difference between two signals of the same frequency can also be measured using a Lissajous' figure by X-Y operation.

In this case, however, the frequency band of the X-axis is 1 MHz (-3dB) thus causing a phase difference of 3° or less at 100 kHz between X and Y.

$$\sin \theta = \frac{B}{A} = \frac{2B}{2A}$$

$$\theta = \sin^{-1} \frac{B}{A}$$

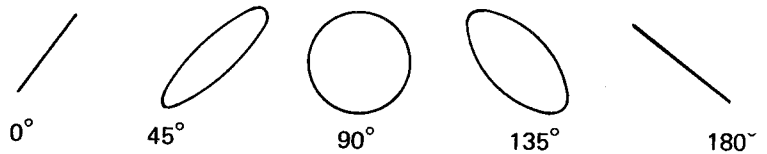
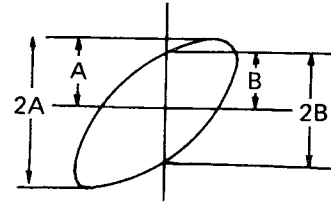

Place the Lissajous' figure on the center line of the scale both horizontally and vertically.

This X-Y operation can effectively be used to display the input and output characteristics of all kinds of electric circuits.

Also, to measure TV color hue, there is a method of displaying 10 colors of the gated rainbow pattern by X-Y operation (making use of a color bar pattern generator such as LEADER Model LCG-391).

Phase relationships of the gated rainbow signal

The ten gated rainbow signals have the phase relationships as shown in the following figure. The color tint pattern (VECTOR) is obtained by applying the B-Y SIGNAL to the X-axis and the R-Y SIGNAL to the Y-axis.

Feed the gated rainbow signals obtained from the color bar pattern generator to the color TV set.

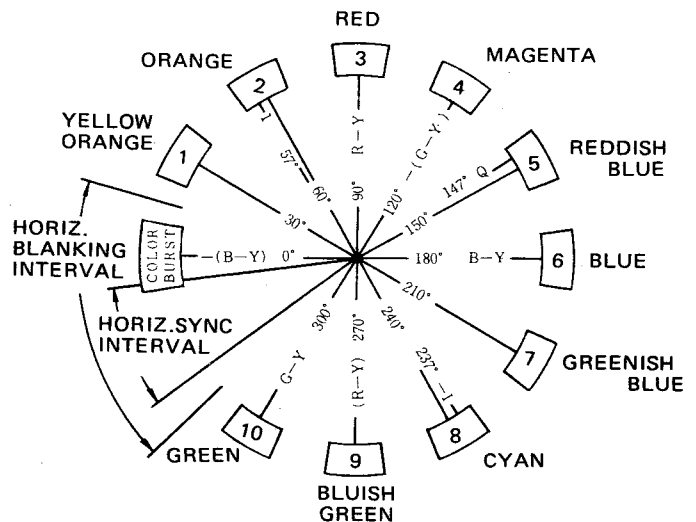

The floral pattern rotates as the TINT or HUE knob of the TV set is turned. If the pattern spreads long instead of getting round, color saturation is responsible.

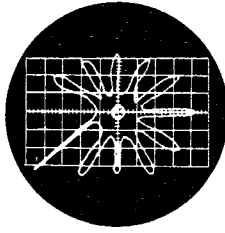

Vector pattern

For more accurate measurement, use of the LVS-5850 Vector Scope is recommended.

7. MAINTENANCE CALIBRATION BY THE USERS

⊘ ROTATION

The ROTATION (beam rotation) ⑨ adjustment screw provided on the front panel is used to adjust

6.9 Intensity Modulation Terminal (Z axis)

Intensity modulation can be obtained when a voltage of 0V to +5V is applied to this terminal in DC coupling under ordinary intensity condition. When a voltage of +2V to +5V (by a intensity control position) is applied, the trace line on the CRT will be erased. When a voltage of 0V to +1V (by a intensity control position) is applied, the trace line will be intensified. That is, the instrument is used to erase a certain part of the trace line on the CRT or to intensify a certain part of the trace line in particular.

a tilt of the horizontal trace when it is caused by the terrestrial magnetism. Check if the tilt is caused by other external magnetic field source.

8. INTERNAL MAINTENANCE CALIBRATION BY SPECIALISTS

It is highly recommended that the internal adjustments described in this section be made by the specialists such as the LEADER's service engineers.

Before making the internal adjustments, the power of within $\pm 3\%$ of the rating voltage should be applied, and aging of at least 30 minutes must be made.

Particularly, the BAL adjustment was made considering the environment temperature, and thus it should be calibrated in a temperature range of 15° to 25°C.

To open the cover, unscrew the upper 5 screws and lower 2 screws.

Disconnect AC power cord from the line.

WARNING: AFTER TURNING OFF THE POWER, VOLTAGES OF -2 kV/+5 kV STILL REMAINS INTERNALLY. WAIT 5 TO 10 MINUTES.

8.1 Layouts of Main Parts and Adjusters

8.1.1 Layout of main parts (Top view)

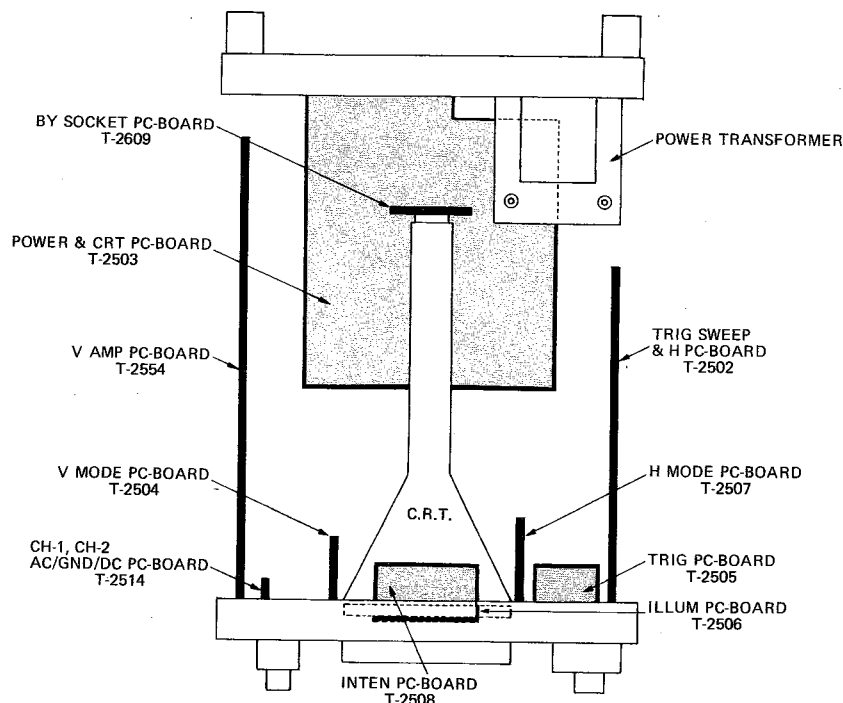

8.1.2 Layout of adjusters

T-2502 TRIG SWEEP & H PC-BOARD (Components side view)

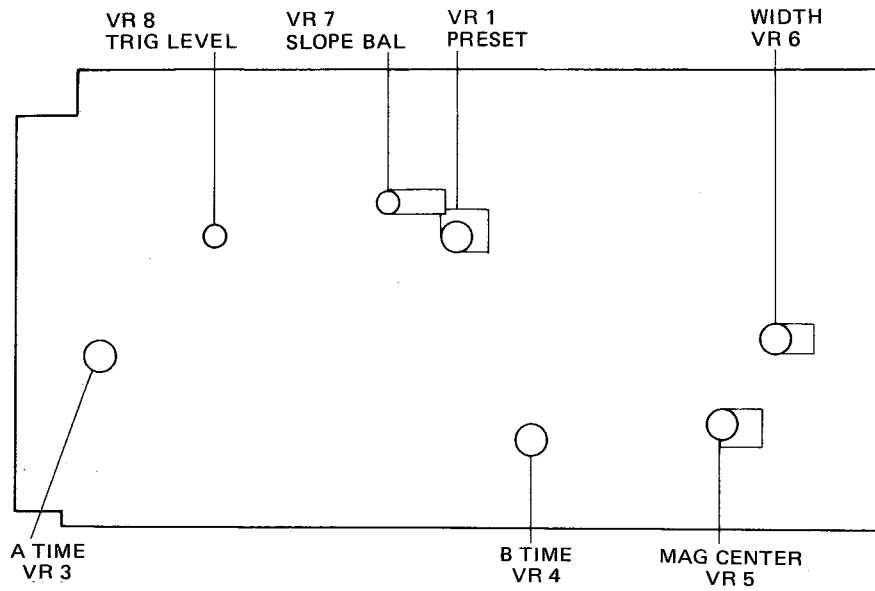

T-2503 POWER & CRT PC-BOARD (Components side view)

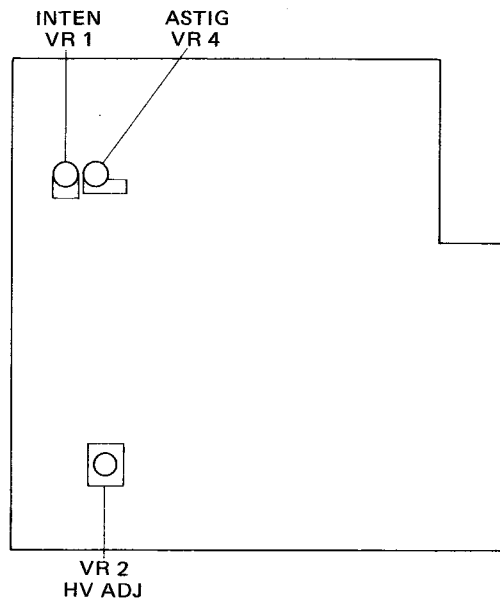

T-2554 V AMP PC-BOARD (Components side view)

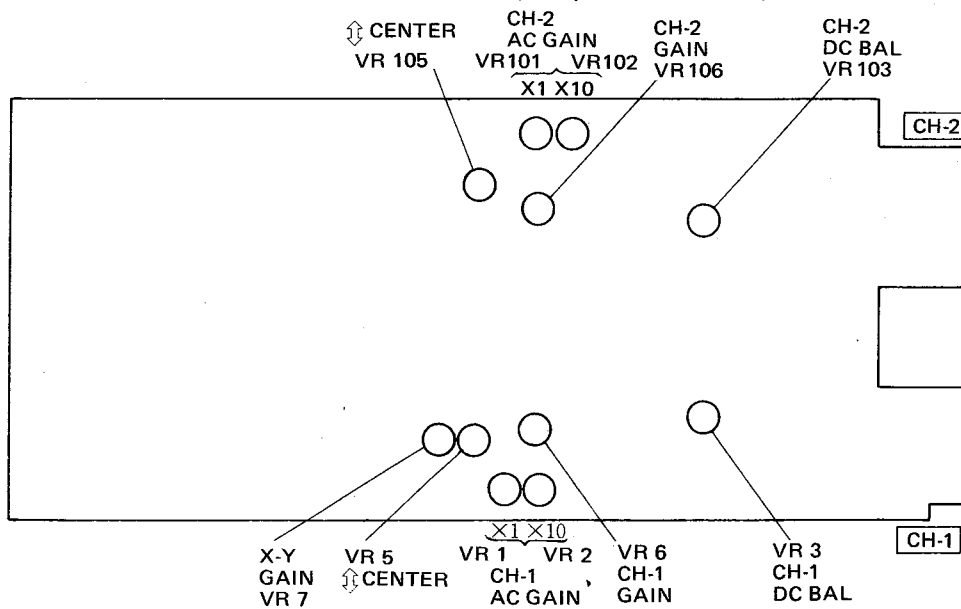

8.2 Adjustments of Main Adjusters

Adjustment method which requires no special measurement instruments will be described below. For full-scale adjustment, use of the LOC-7005 Oscilloscope Calibrator is recommended.

8.2.1 Vertical gain (T-2554) VR6, VR106

The \odot CH-1 GAIN and \odot CH-2 GAIN for both the channels should be calibrated with the same range. Particularly, for dual-trace operation, the adjustments should be made with no sensitivity difference between the channels.

(Example)

Set both the channels in 0.1 V/DIV, DC, and the VARIABLE to CAL'D position, and apply rectangular waveform of 0.5 Vp-p to their input terminals for dual-trace operation.

Then adjust the \odot CH-1 GAIN and \odot CH-2 GAIN to get the same amplitude of 5 div. each for both the display waveforms.

8.2.2 Vertical DC balance (T-2554) VR3, VR103

While the AC/GND/DC switch is set to GND, if the vertical position unusually moves, e.g., as much as 1 div., when the V VARIABLE knob is turned or the VOLTS/DIV switch is switched, adjust the \odot CH-2 DC BAL (VR3, VR103).

- (1) Pull the $\textcircled{14}$ CH-1 VAR and $\textcircled{18}$ CH-2 VAR knobs to make them in the magnification of X10.
- (2) Set both the $\textcircled{21}$ $\textcircled{26}$ AC/GND/DC switches to GND.
- (3) Set both the $\textcircled{15}$ $\textcircled{19}$ VOLTS/DIV switches to 5 mV/div. range.
- (4) Turn both the $\textcircled{14}$ $\textcircled{18}$ VARIABLE knobs full counter-clockwise.
- (5) Adjust both the $\textcircled{13}$ $\textcircled{24}$ \updownarrow POSITION knobs to locate the trace lines in the middle of the screen height.
- (6) Turn the $\textcircled{14}$ $\textcircled{18}$ VARIABLE knobs full clockwise.

(7) Restore the moved trace lines to the center by adjusting the \odot DC BAL (VR3, VR103).

(8) Repeat the above procedure 2 to 3 times until the trace lines do not move.

8.2.3 \odot ASTIG (T-2503)

When a sharp trace of waveform is not available by the adjustment of the $\textcircled{10}$ FOCUS knob alone on the front panel, adjust the ASTIG screw.

The ASTIG condition can be determined when the focus is made dull. Adjust the ASTIG to make the trace dull to all the directions equally, when it is necessary.

By the nature of a CRT used, display image on circumference of the CRT becomes dull always.

Avoid use of a spot for the adjustment; otherwise the fluorescent material on the screen may be burnt.

8.2.4 Calibration of time axis (T-2502)

An oscillator having the frequency accuracy of 1% or better in combination with a frequency counter is used to obtain the calibration signals.

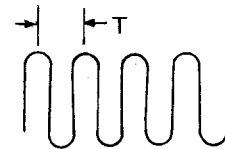

f	T
100 Hz	10 ms
200 Hz	5 ms
500 Hz	2 ms
1 kHz	1 ms

f	T
2 kHz	0.5 ms
5 kHz	0.2 ms
10 kHz	0.1 ms
20 kHz	50 μ s

The A TIME is adjusted by the \odot VR3, and the B TIME is adjusted by the \odot VR4.



Becomes dull to the vertical direction



Becomes dull to all the directions (Good)



Becomes dull to the horizontal direction

9. CONNECTION DIAGRAM AND SCHEMATICS

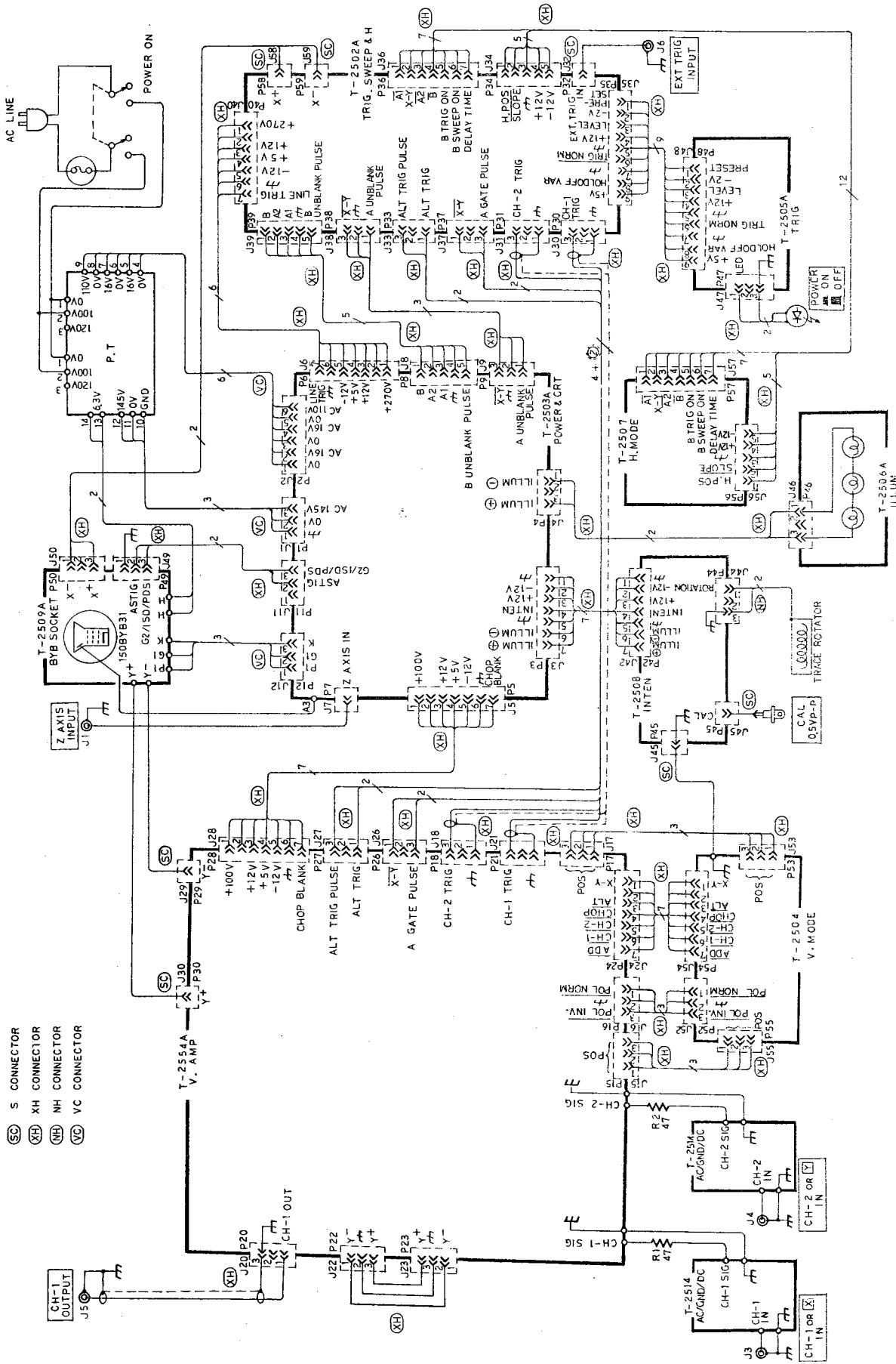

- (S) S CONNECTOR
- (XH) XH CONNECTOR
- (NH) NH CONNECTOR
- (VC) VC CONNECTOR

SCHMATIC	Model LBO-524	O-1435 (1/9)
PCB & WIRE CONNECTION LEADER ELECTRONICS CORP.		

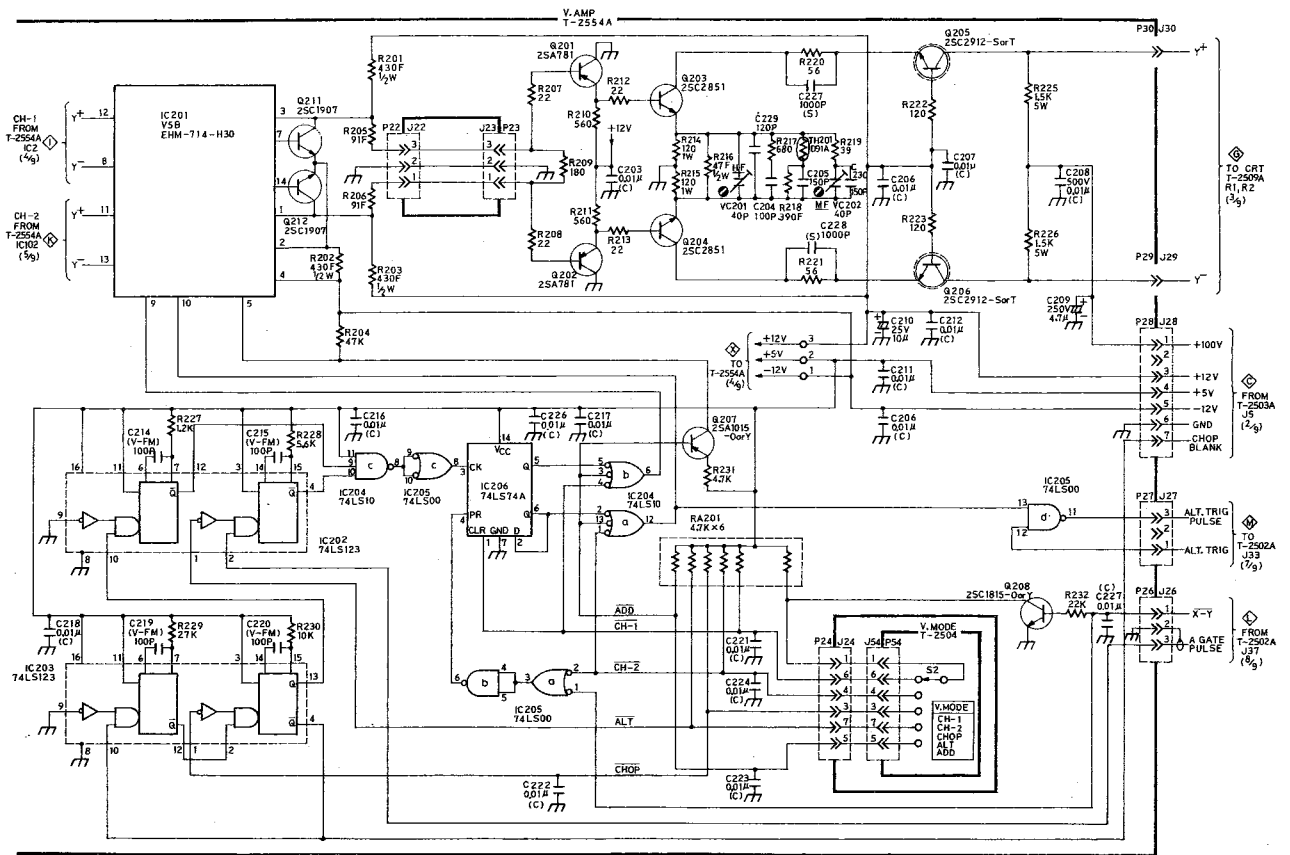

SCHEMATIC	Model LBO-524	0-1435 (1/2)
	VERT MODE & FINAL AMP	LEADER ELECTRONICS CORP.

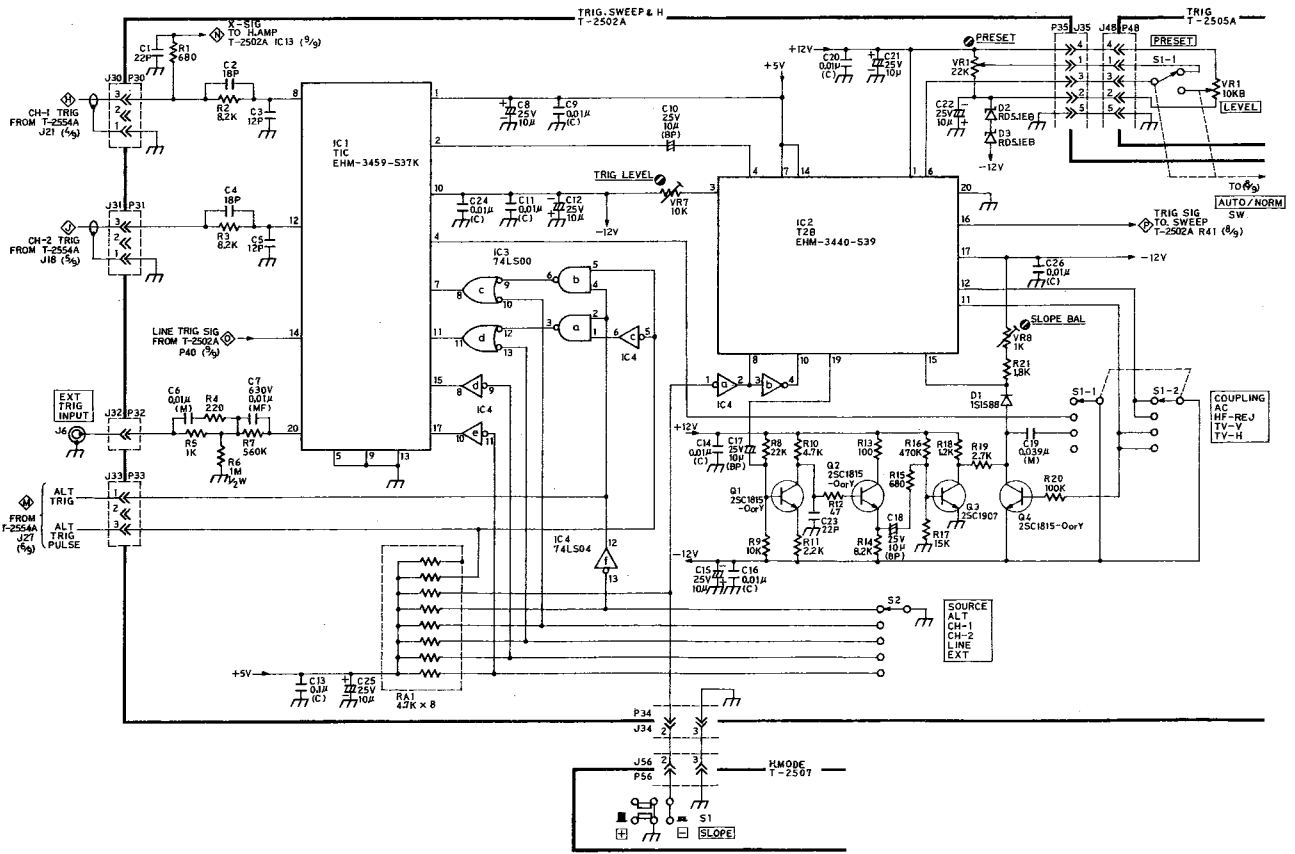

SCHEMATIC	Model LBO-524	0-1435 (1/2)
	TRIG. AMP	LEADER ELECTRONICS CORP.

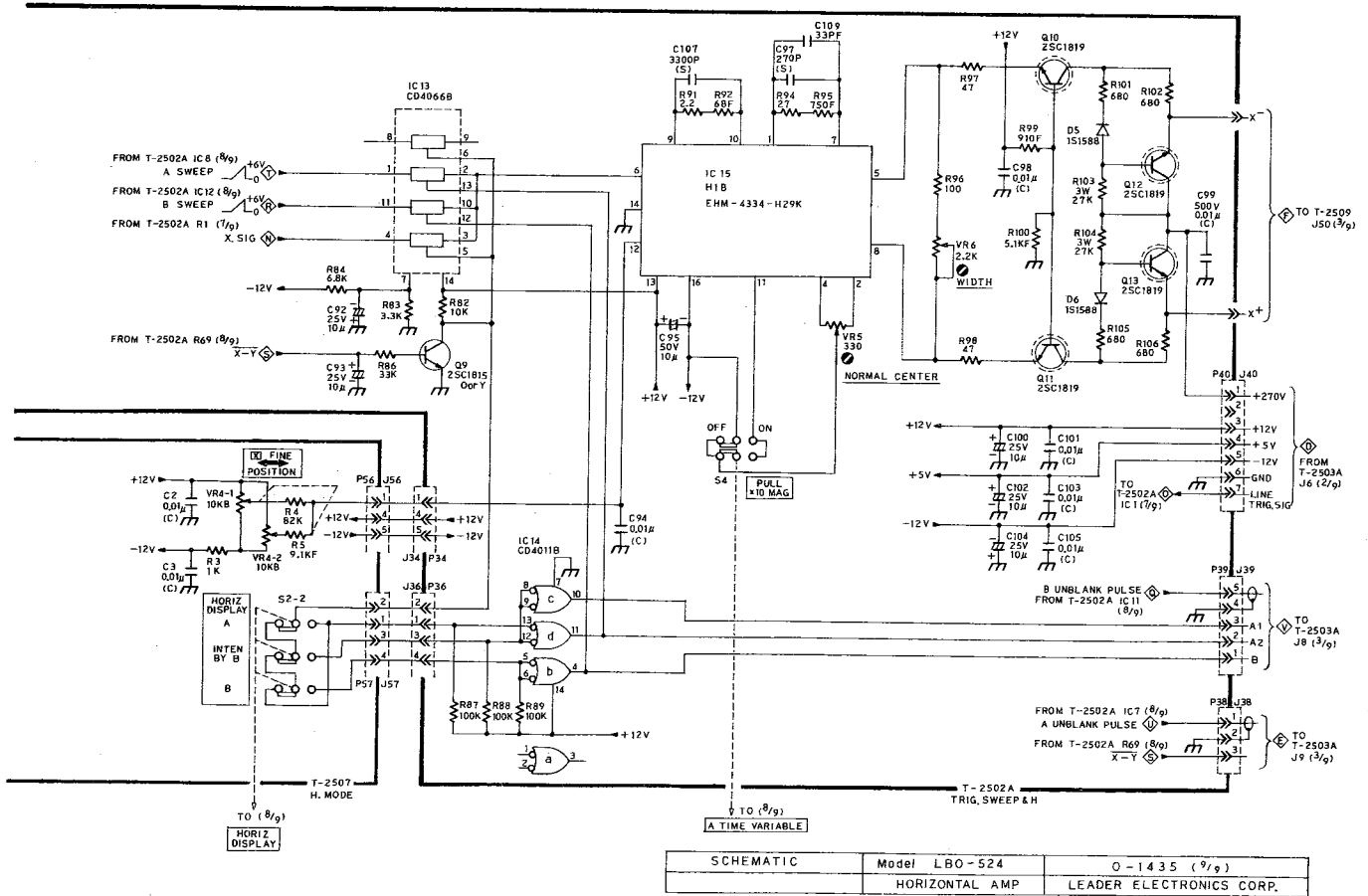
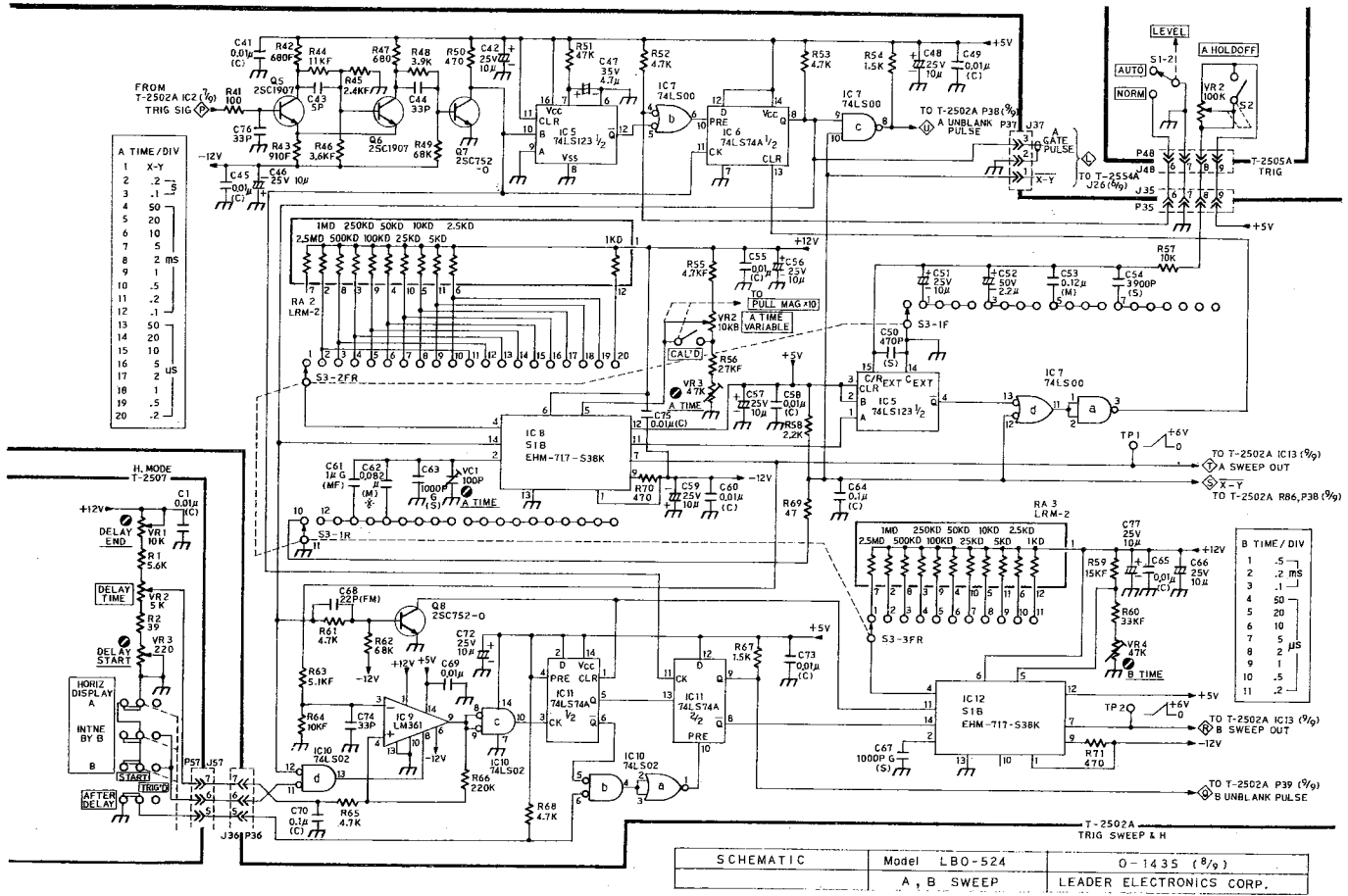

LEADER TEST INSTRUMENTS

LEADER ELECTRONICS CORP.

2-6-33 TSUNASHIMA-HIGASHI, KOHOKU-KU,
YOKOHAMA, JAPAN.

PHONE: (045) 541-2121 TELEX: J47780 JPLEADER

LEADER INSTRUMENTS CORP.

380 OSER AVENUE, HAUPPAUGE, N.Y. 11788 U.S.A.

PHONE: (516) 231-6900

TELEX: 510-227-9669 LEADER HAUP